

MILAN

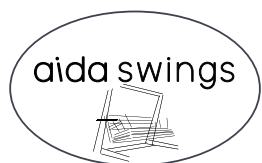



Sayın Müşterimiz,

Satınalmış olduğunuz bu ürün sizlere ulaşmadan önce tarafımızdan her türlü kontrol ve testlere tabii tutulmuştur. Bu durumda bile taşıma sırasında bazı parçaların zarar görmesi mümkündür. Böyle bir durum ile karşılaşırsanız ürünün tamamını geri göndermeyiniz. Sadece zarar gören parçayı isteyiniz. Gerekli parçayı isterken ise servis kartına bakarak tam olarak tanımlayınız. Eksik olan parça en hızlı şekilde tarafınıza gönderilecektir.

Montaja başlamadan önce kutulardan çıkan tüm parça ve aksesuarları listelere göre kontrol ediniz. Parça ve aksesuarların tam ve sağlam olduğunu tespit ettikten sonra montaja başlayınız.

Montaja başlamadan önce her parçayı nemli bir bez ile temizleyiniz.

Eğer birden fazla ürün aldıysanız herhangi bir karışıklığa sebep vermemek için tek bir ürün montajını yaptıktan sonra diğer ürüne geçiniz.

Ürünleri hiçbir zaman sürterek taşımayınız. Ürünü kaldırarak ve sökerek en az iki kişi ile taşıyınız. Uzun mesafeli taşımalarda ürünü mutlaka paket ile taşıyınız.

Almış olduğunuz mobilyalarınızın yüzeylerinin temizlenmesi çok kolaydır. Nemli ve sabunlu bir bez ile veya diğer ev temizleyicileriyle silmek yeterlidir.

Mobilyalar aşırı sıcak, soğuk ve nemden etkilendiklerinden, mobilyanızı bu faktörlerle direkt olarak temas ettirmeyiniz.

Mobilyanızı amacı dışında kullanmayınız.

Dear Customer,

The product you bought was subjected to all sorts of tests and control before sending out to you. Even in this situation, sometimes happen that some component is damaged during the transportation. In such case please do not send the whole article back to us. Just request/order the damaged part. While requesting the required part, describe it exactly by looking to service card. Missing part will be sent to you as soon as possible.

Before start assembling, please check the whole components and accessories according to the lists. After being sure that every part and accessory are okay and right, start assembling.

Before start assembling, please clean all the components with a damp cloth.

If you bought more than one product, to prevent confusion be sure that you completed the first product. Then start the other product's assembling.

Never draw the products. While carrying, disassociate and lift the product and carry with minimum 2 people. For long distances carry the product with the package.

It is very easy to clean the surfaces of your product. It is enough to wipe with a damp and soapy cloth or other household cleaners.

Do not directly contact your furniture with excessive heat, cold and humidity because the product can be affected.

Do not use your furniture for out of purposes.

Lieber Kunde,

das von Ihnen gekaufte Produkt durchläuft verschiedene Tests und Prüfungen bevor es zu Ihnen kommt. Trotzdem kann es vorkommen, dass während des Transports ein Teil beschädigt wird.

In solchem Fall bestellen Sie anhand der Servicekarte das beschädigte bzw. das fehlende Teil. Wir werden Ihre Anforderung sofort bearbeiten und Ihnen das Ersatzteil umgehend zusenden.

Kontrollieren Sie vor der Montage anhand der Zubehörliste alle Teile und Accessoires auf Vollständigkeit. Erst nach dieser Überprüfung können Sie mit der Montage beginnen.

Falls Sie mehr als ein Produkt gekauft haben, montieren Sie erst das eine und danach das andere Produkt, damit Sie mit den Teilen nicht durcheinander kommen.

Der Transport von fertig montierten Möbeln sollte immer von zwei Personen erfolgen.

REINIGUNG

Reinigen Sie die Teile mit einem leicht feuchten Tuch, danach trockenreiben. Keine scheuernden oder ätzenden Reinigungsmittel verwenden.

Hohe Hitze und Feuchtigkeit schaden Ihren Möbeln, bitte von diesen Quellen fernhalten.

Möbel bitte nicht zweckentfremden.

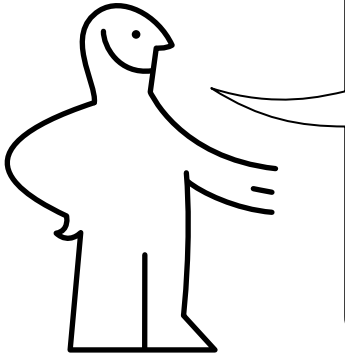

T 40



Bu modülün kurulumu için gerekli olan araçlar.
The necessary tools (not included)
Die dazu benötigten Werkzeuge

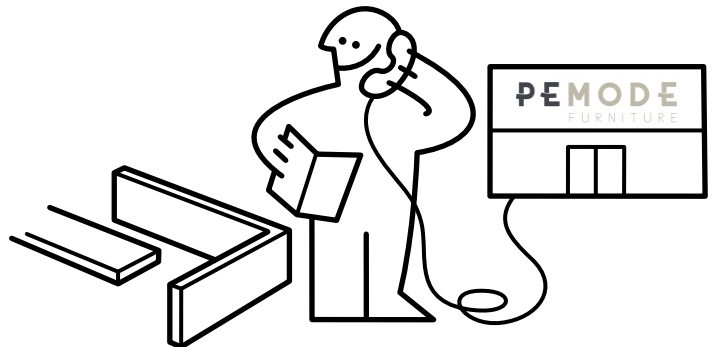
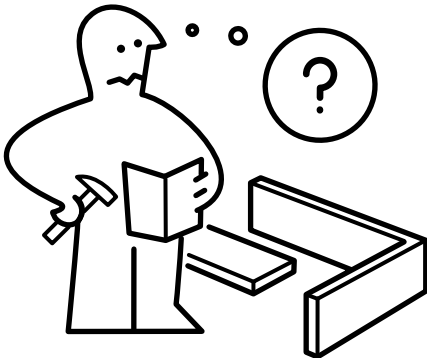
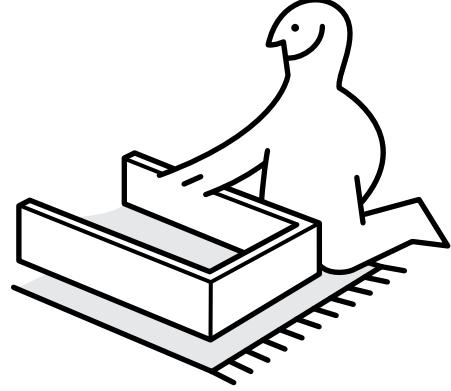
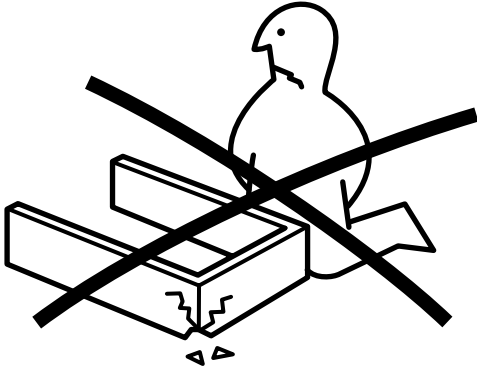
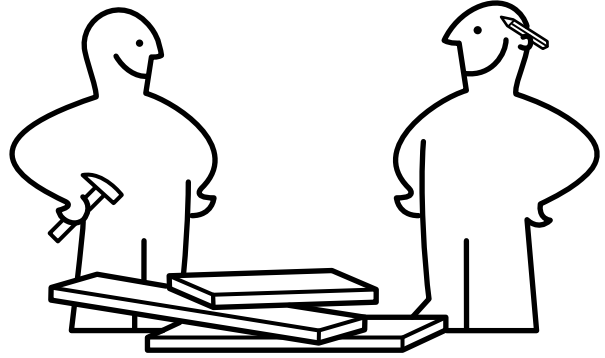
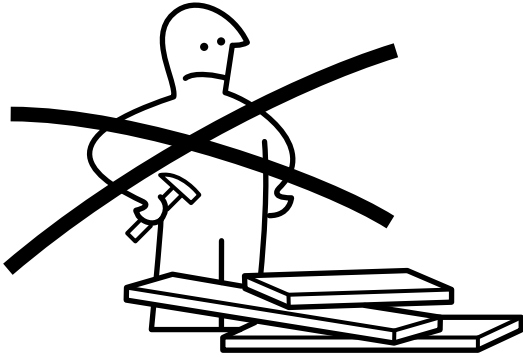

info@pemode.com.tr

MILAN



H15004003016 (8x80)

6x



H15004007004 (30x10x1)

6x



H15004016002 (T40)

1x



H15004012001 (T30/T40)

1x

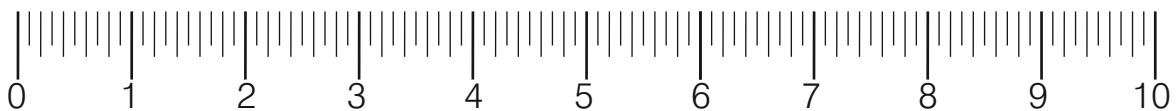

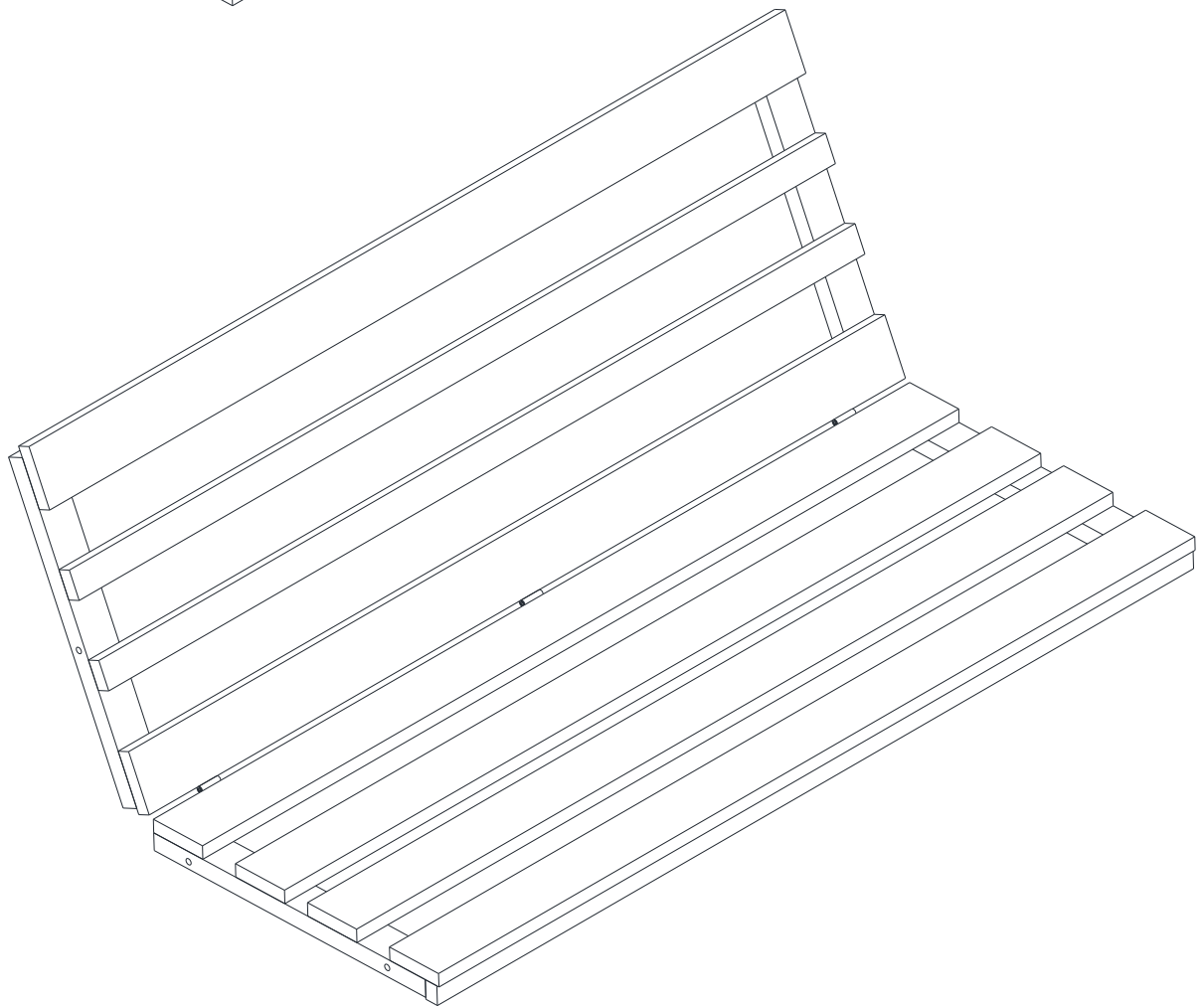
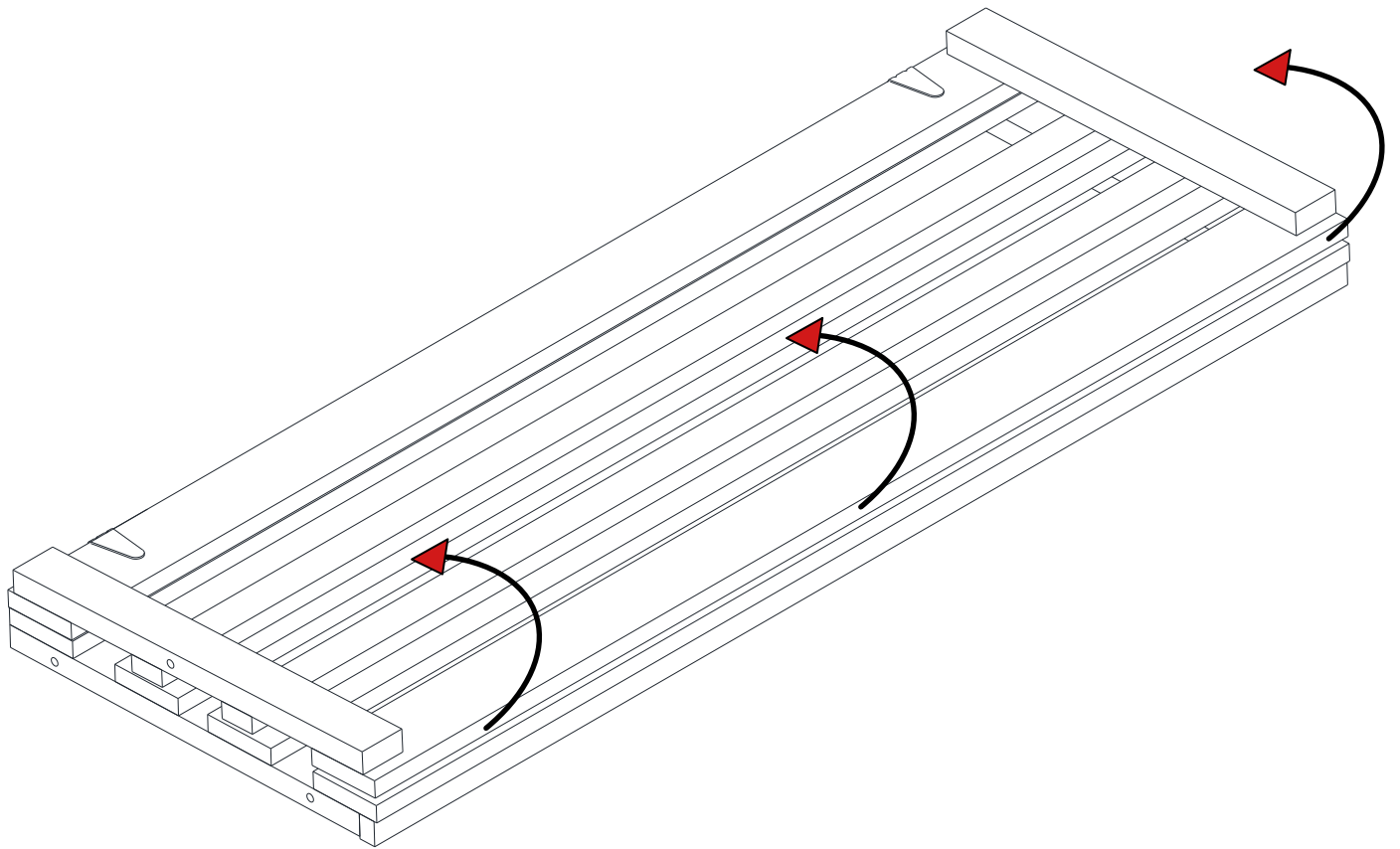

H15004003016 (8x80)



3x

3x

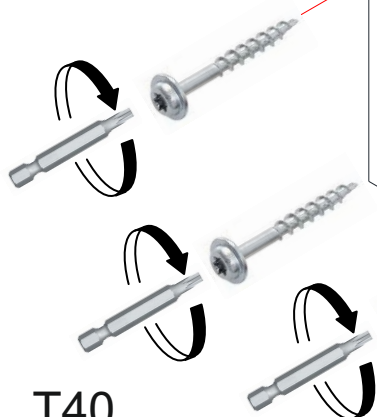

T40

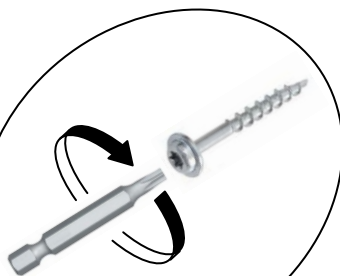

3x

H15004007004 (30x10x1)



3x



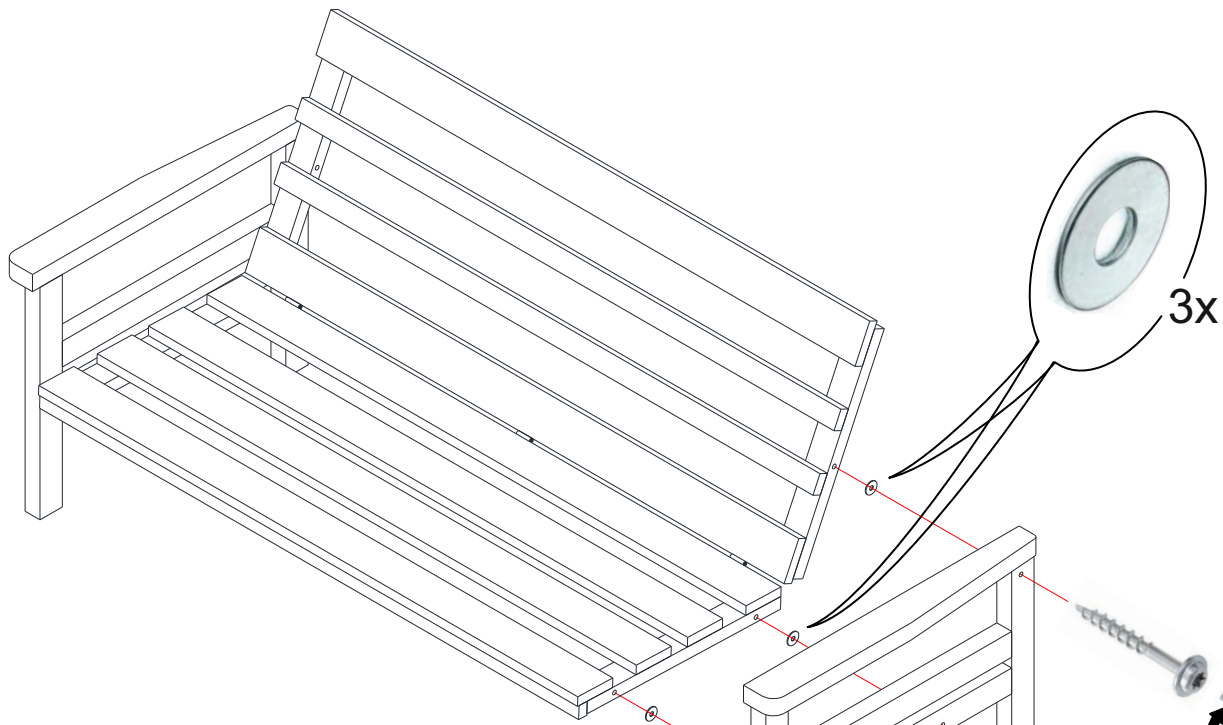

H15004003016 (8x80)



3x

H15004007004 (30x10x1)



3x

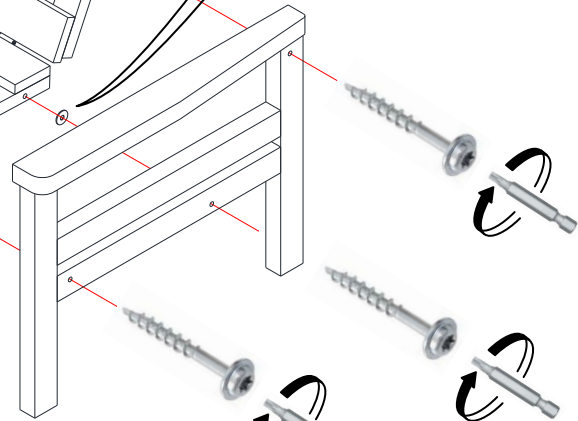

T40

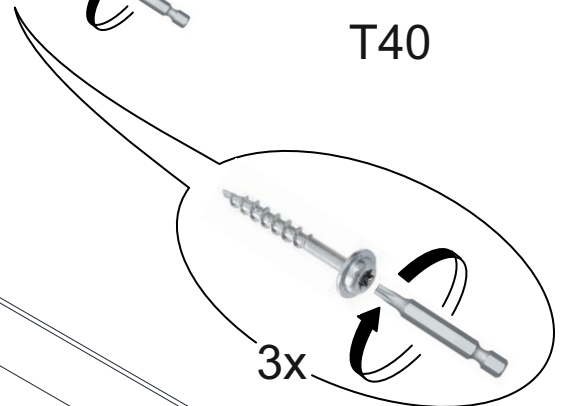

3x

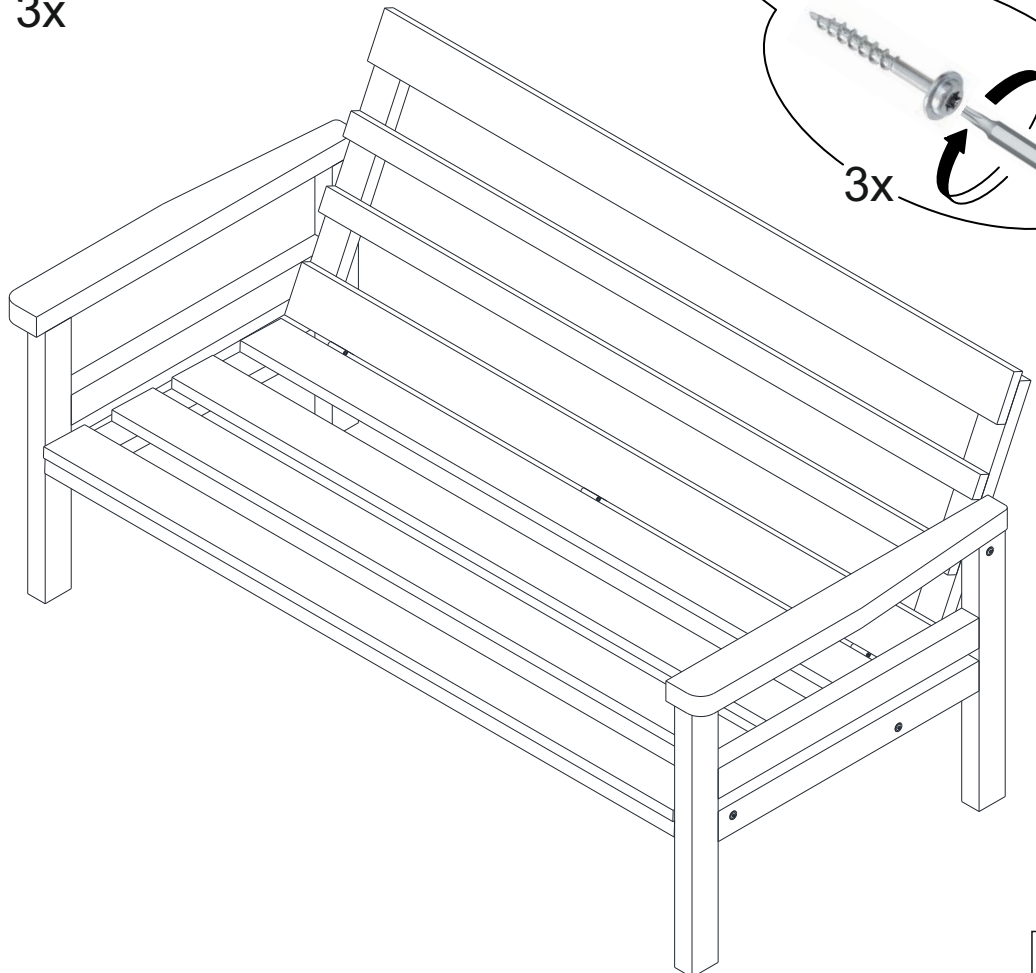

aida swings

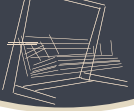

MILAN



PEMODE MOBİLYA VE
İNŞ. SAN. TIC. LTD. ŞTİ.

Çanakkale OSB mevki 1.cad No:66
Karacaören - Merkez | Çanakkale
TURKEY

Email: info@pemode.com.tr
aidaswings@pemode.com.tr

www.aida-swings.com
www.pemode.com.tr

Tel: +90286 217 94 44
Fax: +90286 217 94 34