

# ZENITH

## STUDY TABLE

---

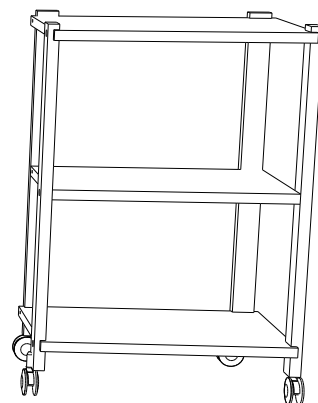

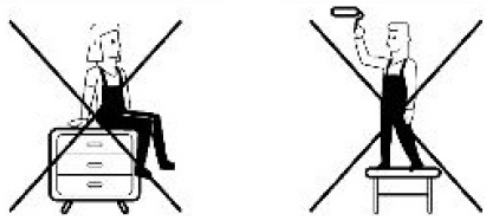
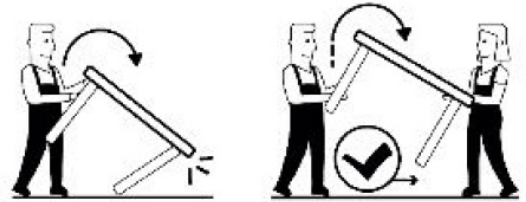
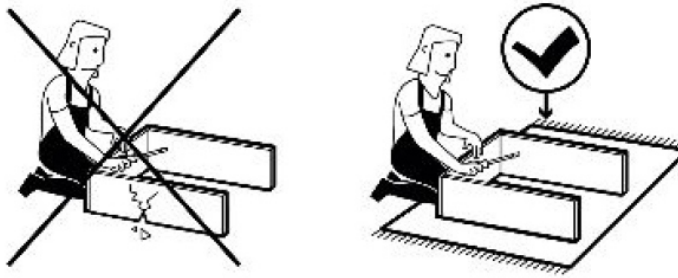
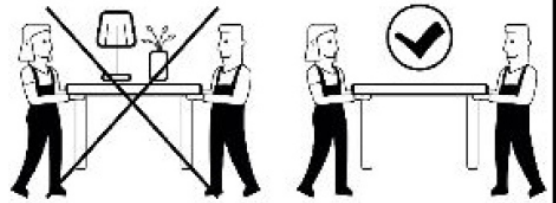
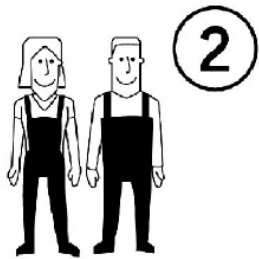

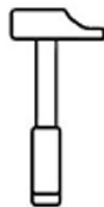

0286 316 80 80

info@lagomood.com

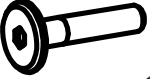

# ACCESSORY LIST

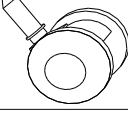
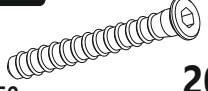
<b>A1</b>  1x	<b>A2</b>  16x	<b>A3</b>  4x	<b>T01</b>  4x	<b>A10</b> KBN VDS  6x50 20x
--	---	--	---	--

## GENERAL VIEW

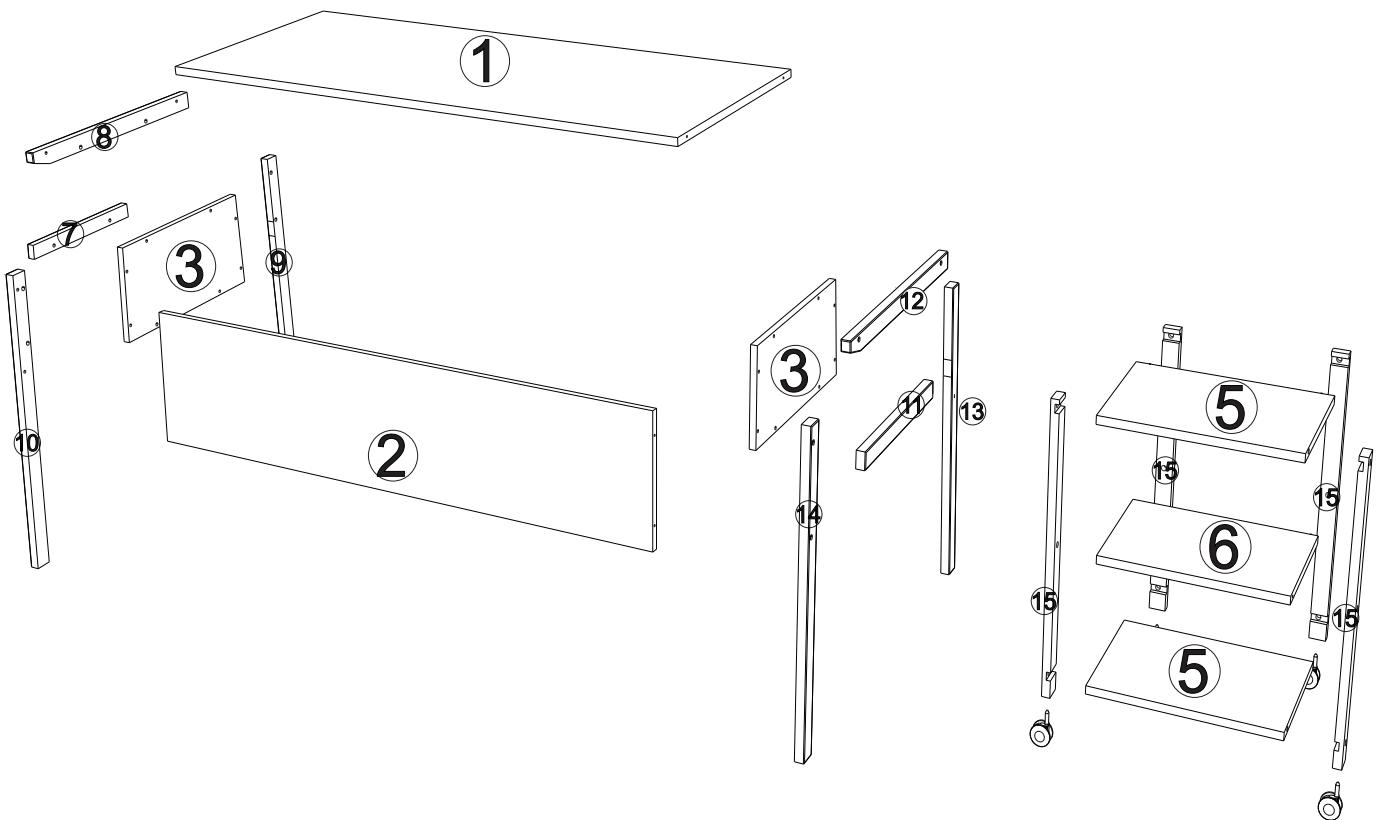

1

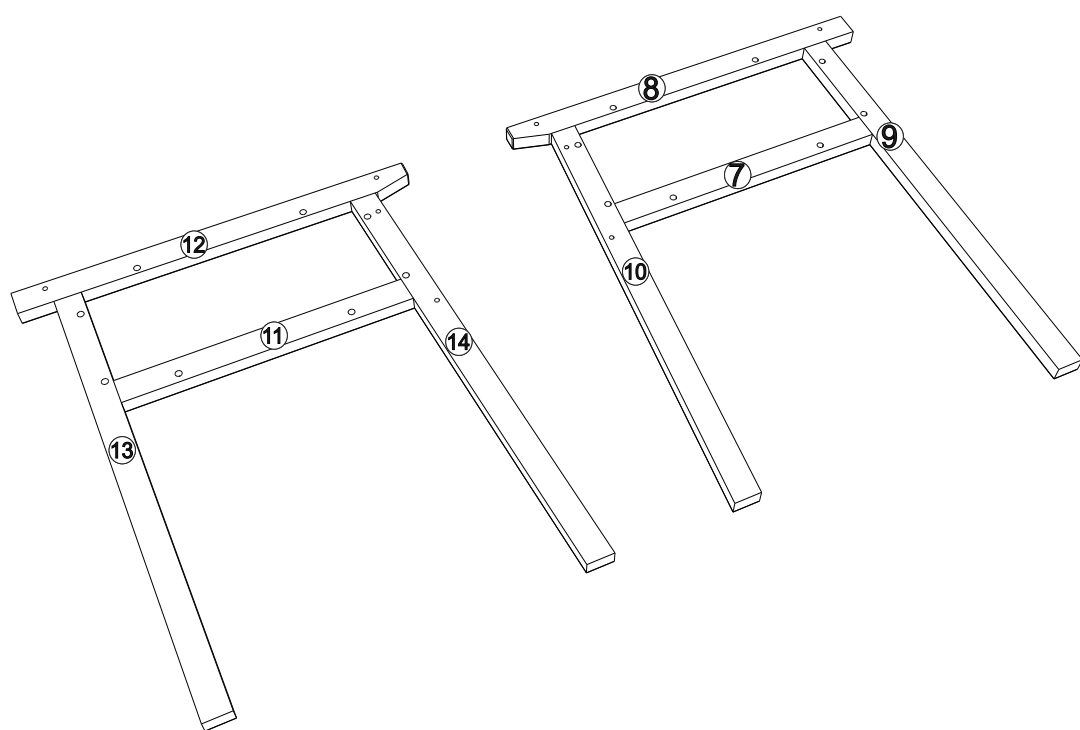

2

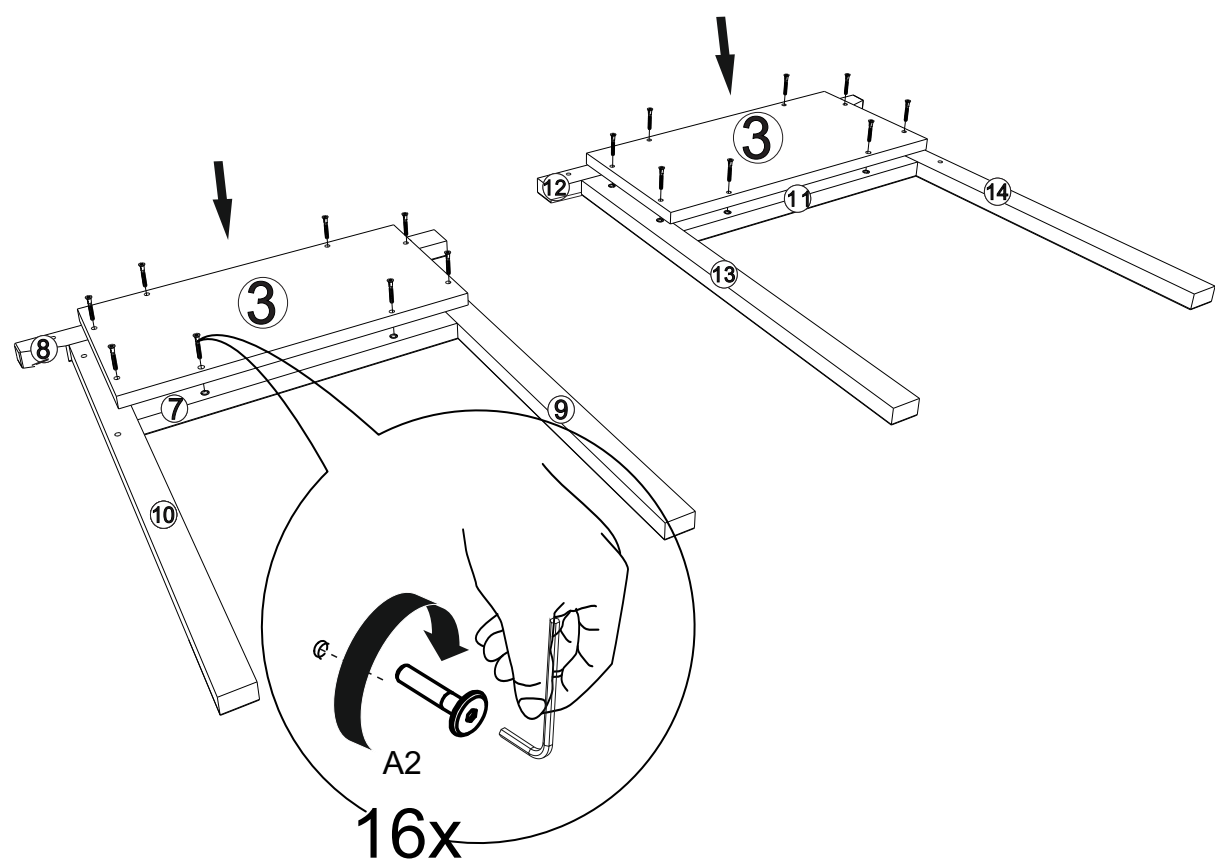

3

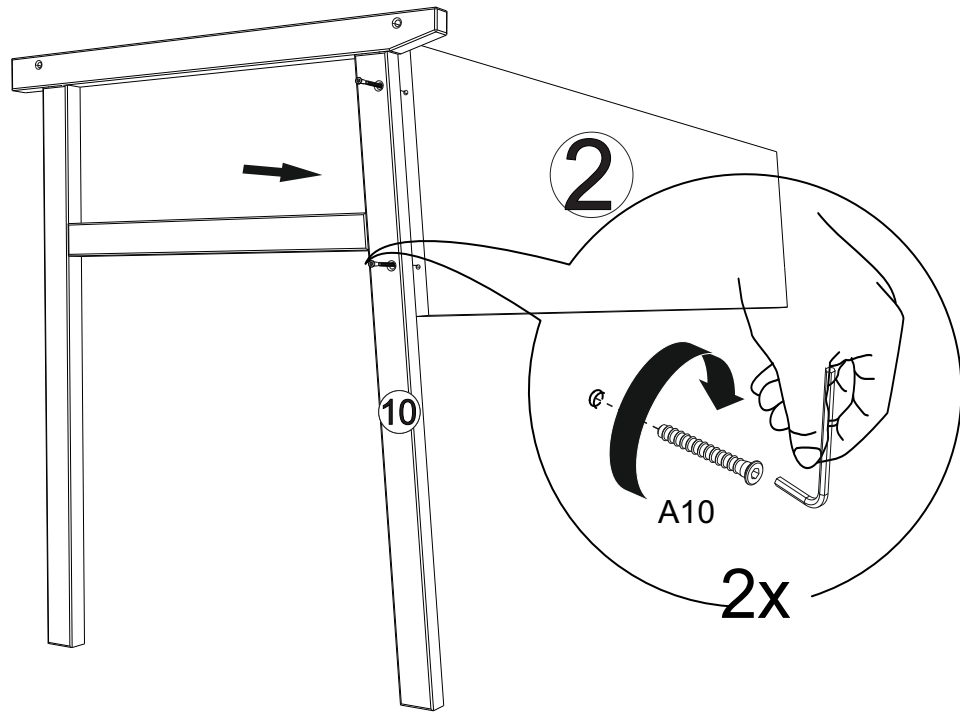

4

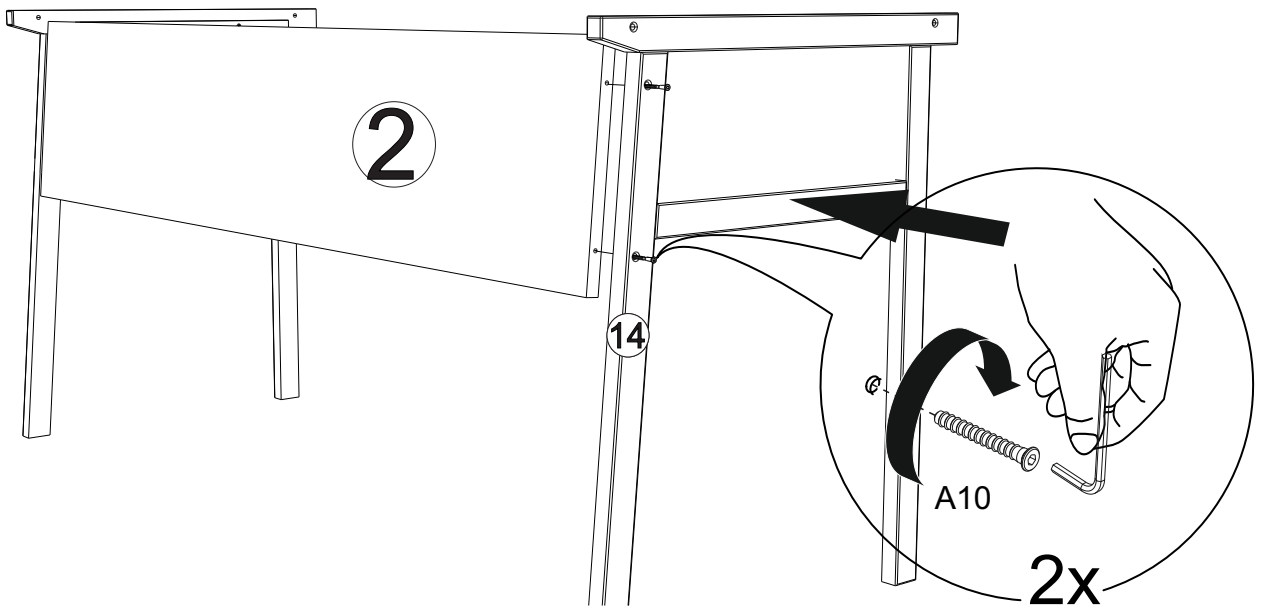

**5**

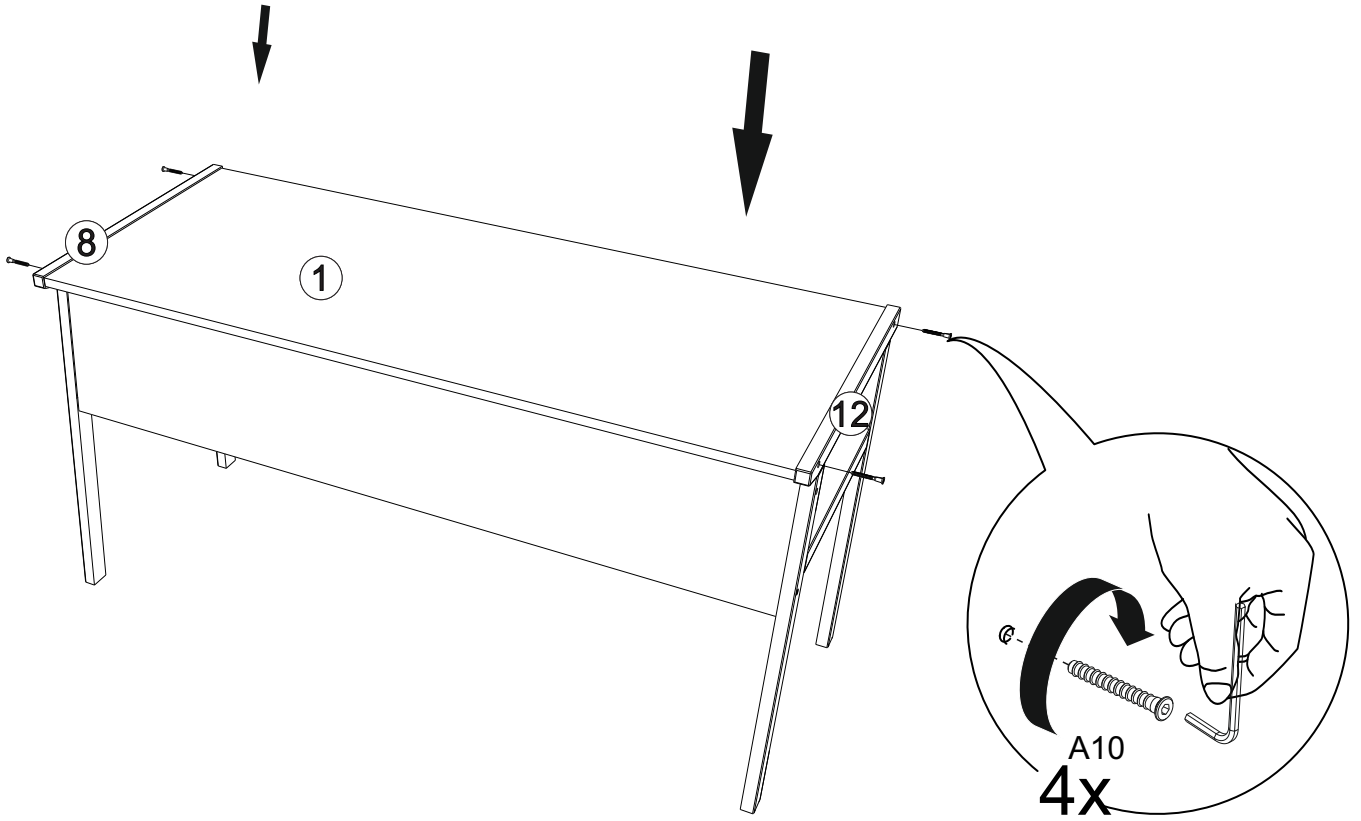

**6**

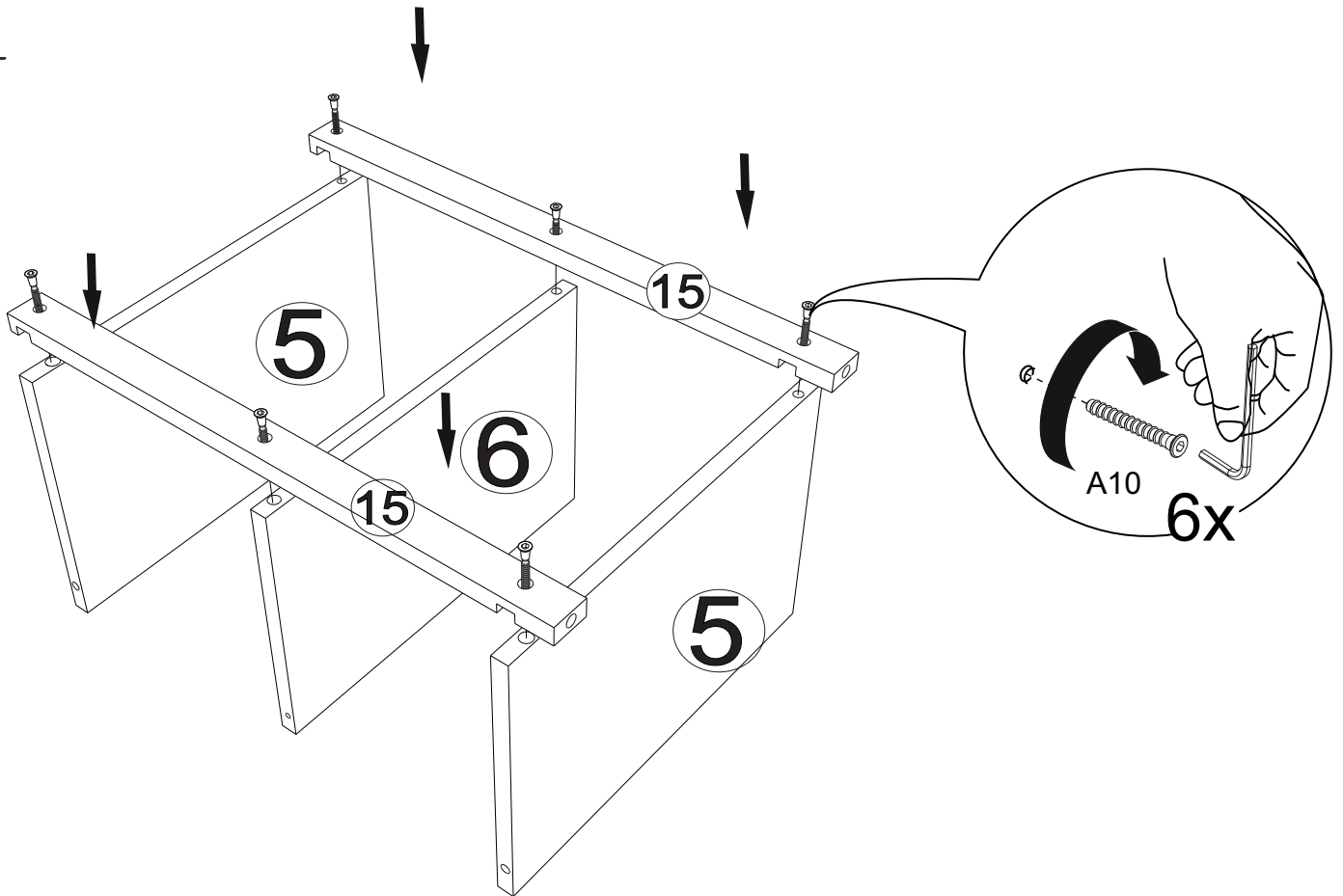

7

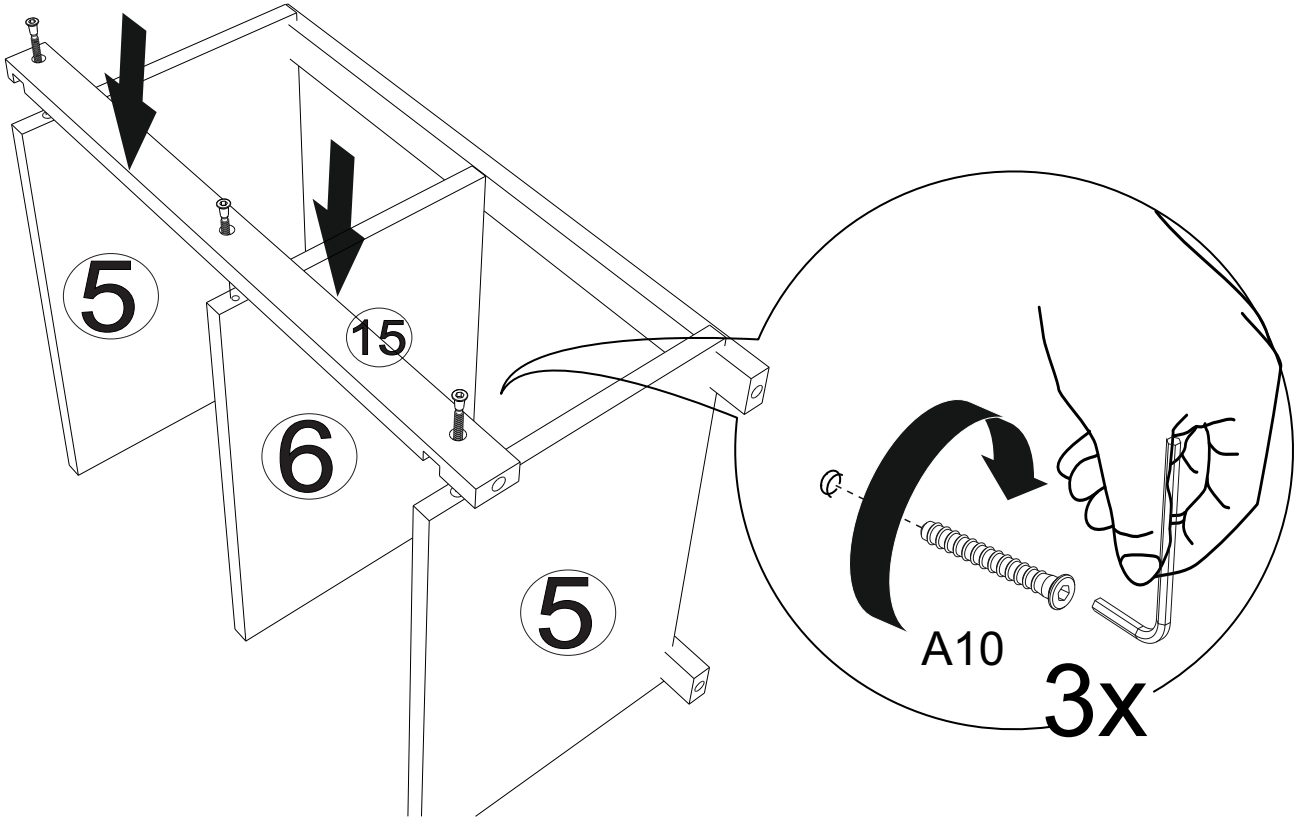

8

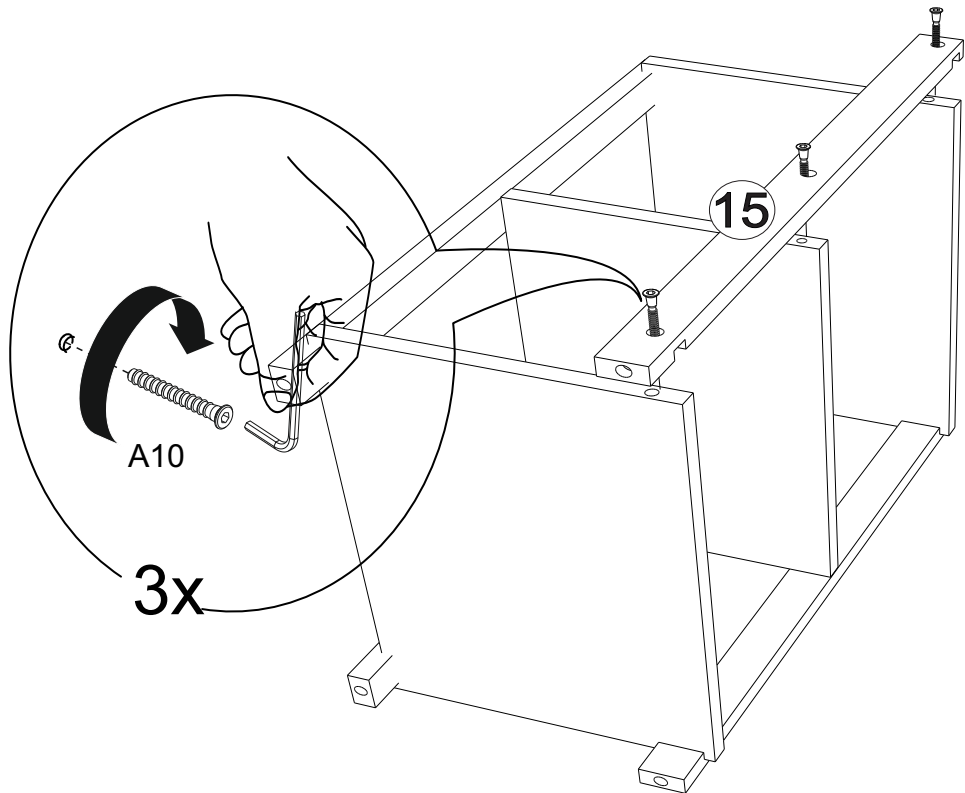

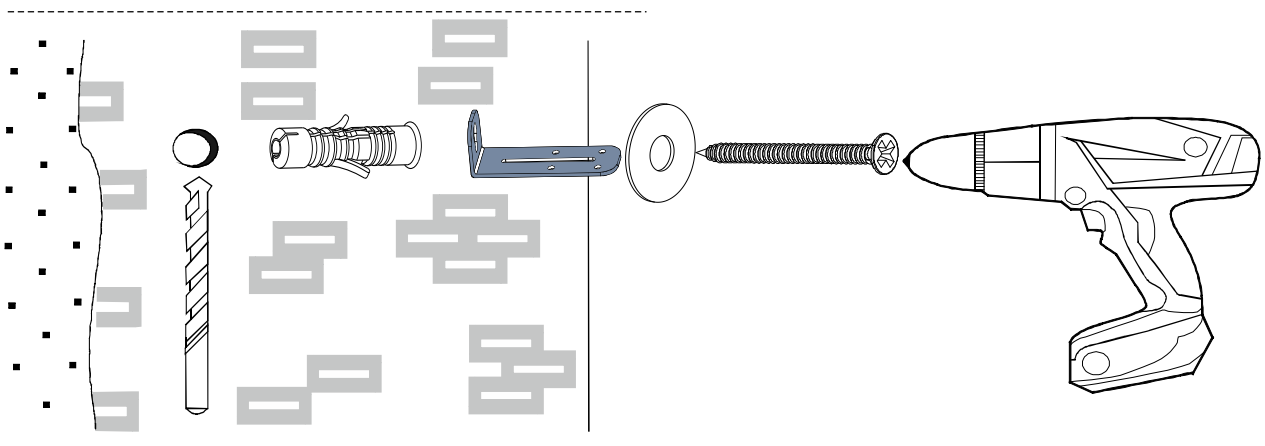
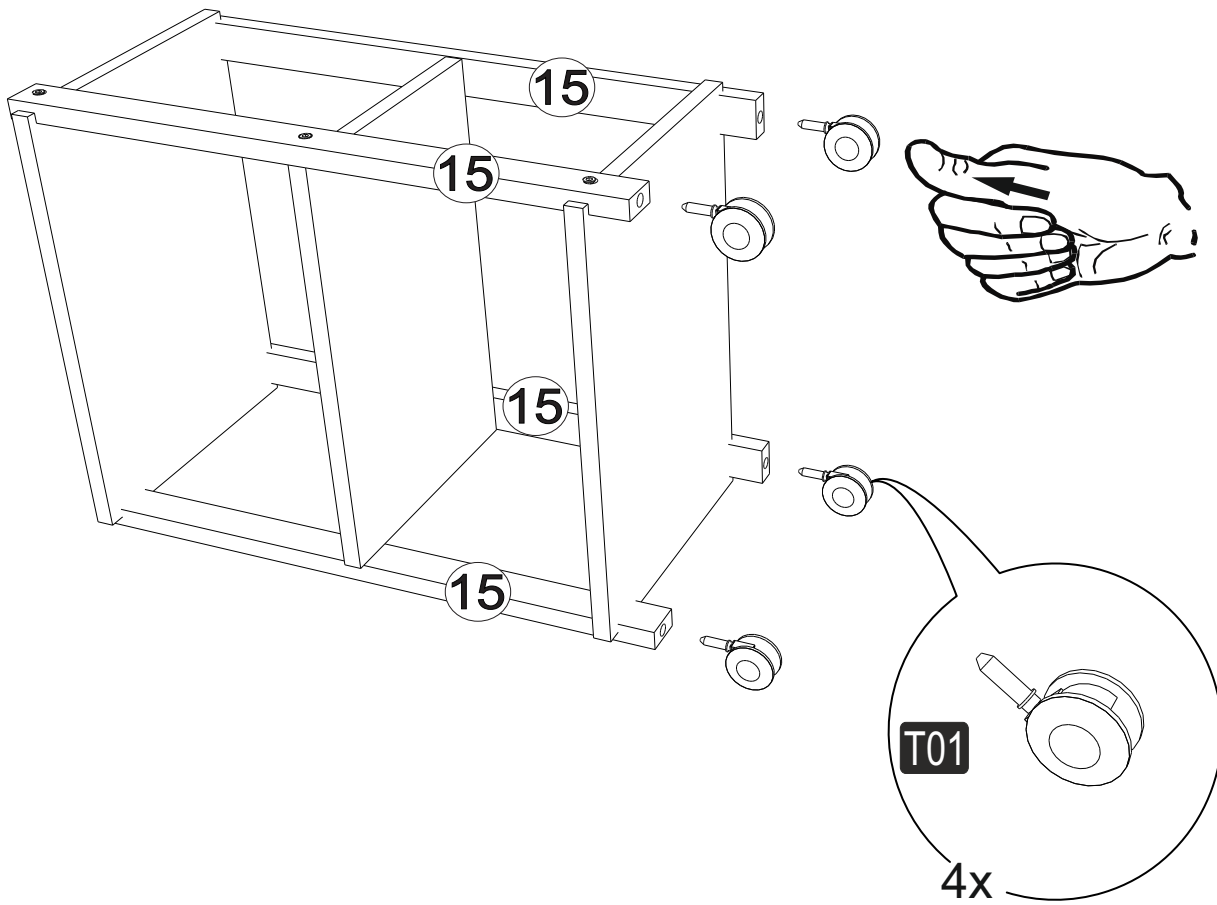

Check the wall type before installation of dowel. Wall is drilled with equal diameter of dowel. (08mm) Universal Plastic Dowel provides the general purpose usage. Requires two stages assembly. Dowel can be different type according to the wall type. (E.g. Plaster sheet partition wall, gas concrete, hollow brick wall). If required, use appropriate dowels and screws.





# **WARNING**

## **CHOKING HAZARD**

- This unit contains small parts which could be a choking hazard for small children. Children should be under adult supervision at all times.
- Do not overload the unit. Each shelf has a recommended capacity of 13 pounds, and the total weight on the unit should not exceed 39 pounds for wall shelves.
- Do not climb, step, or stand on the unit.
- Do not mount or attach items to the front, rear, or sides of the unit. This can cause the unit to become unbalanced and fall.
- Do not stack units.
- All units must be secured individually to wall studs using hardware provided. If wall studs are not accessible, consult your local hardware store for appropriate mounting hardware.
- We recommend you handtighten screws. Use care not to overtighten if using power tools. Follow proper safety procedures if using power tools and/or ladders.
- We recommend you protect your work surface during assembly to prevent scratching or damage to tabletops, wood floors, etc.
- Failure to follow the instructions listed here could result in bodily injury or damage to personal belongings. Use caution and follow safety procedures.