

# T0018

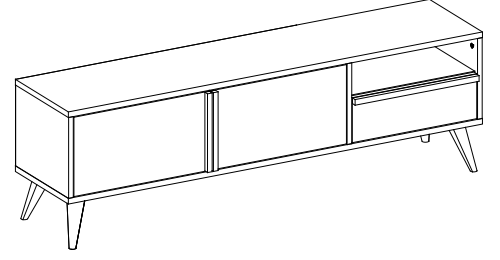

## ASSEMBLY MANUEL - MONTAJ KILAVUZU - AUFBAUANLEITUNG

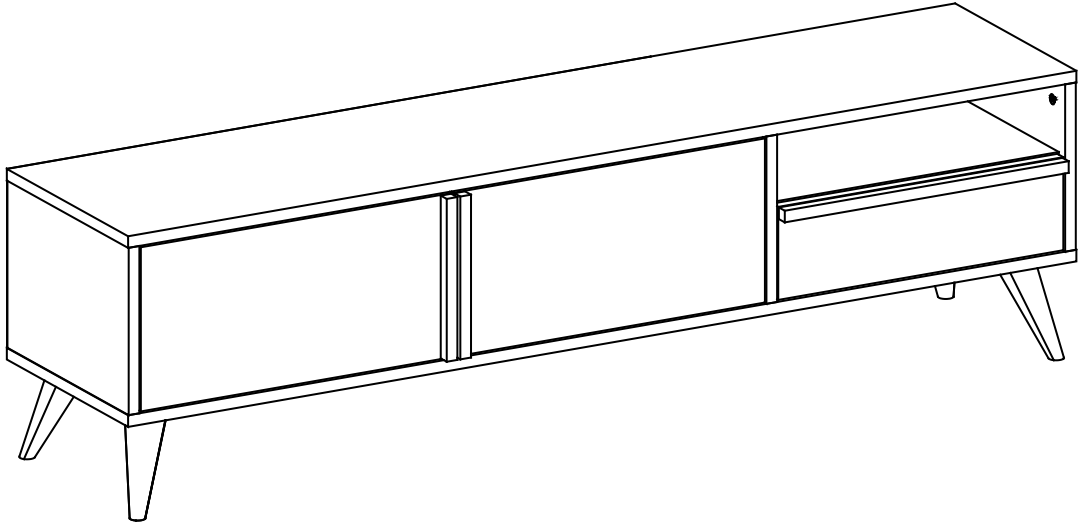

Size daha iyi bir hizmet sunabilmek ve artık ihtiyaç duyulmayan atıkları üretim sürecine geri kazandırabilmek adına lütfen geri dönüşümü destekleyin . Çevreyi koruyarak daha iyi bir DÜNYA için işbirliği yapalım... Bizi tercih ettiğiniz için teşekkür ederiz :)



In order to provide better service to you again and gain to the production process of the use of non - recycled waste material support, please let us... Let us preserve the environment for a better WORLD...Thank you for choosing us :)

Um Ihnen einen besseren Service zu bieten und die nicht mehr benötigten Abfälle wieder in den Produktionsprozess zu bringen, unterstützen Sie bitte das Recycling Vielen Dank, dass Sie sich für uns entschieden haben :)

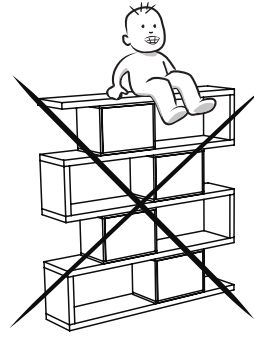

Dear Customer,

The product you bought was subjected to all sorts of tests and control before sending out to you. Even in this situation, sometimes happen that some component is damaged during the transportation. In such case please do not send the whole article back to us. Just request/order the damaged part. While requesting the required part, describe it exactly by looking to service card. Missing part will be sent to you as soon as possible. Before start assembling, please check the whole components and accessories according to the lists. After being sure that every part and accessory are okay and right, start assembling. Before start assembling, please clean all the components with a damp cloth. If you bought more than one product, to prevent confusion be sure that you completed the first product. Then start the other product's assembling. Never draw the products. While carrying, disassociate and lift the product and carry with minimum 2 people. For long distances carry the product with the package. It is very easy to clean the surfaces of your product. It is enough to wipe with a damp and soapy cloth or other household cleaners. Do not directly contact your furniture with excessive heat, cold and humidity because the product can be affected.

I understand that sometimes components can be damaged during transportation. If you encounter any missing or damaged parts, please don't hesitate to contact us. . We're here to help!

Sayın Müşteriler,

Sunduğumuz ürünler, teslimat öncesinde titiz bir kalite kontrolden geçmektedir. Ancak, taşıma sırasında hasar görebilirler. Bu durumda parçaların numarasını bildirmeniz halinde ücretsiz yeni parçaların gönderimini sağlamaktayız. Lütfen doğru parçanın gönderilmesi için montaj kılavuzunda belirtilen parça numarasını kontrol edin. Montaja başlamadan önce, tüm parçaları hasar ve eksiklik açısından kontrol ediniz. Birden fazla ürün satın aldıysanız, karışıklığı önlemek için ürünleri sırayla kurmaya dikkat edin. Parçaları taşırken sürüklemek yerine kaldırarak ve herhangi bir hasarı önlemek için en az iki kişi tarafından taşımanızı öneririz. Uzun mesafeli taşımalarda ürünü kutusunda taşıyınız.

Ürünü temizlemek için nemli bir bez ve evde bulunan temizleyiciler yeterli olacaktır. Lütfen ürününüzü aşırı sıcaklık, soğukluk ve nemden koruyun. Ürünü sadece amaçlandığı şekilde kullanın.

Taşıma sırasında bazen parçalar hasar görebilir. Eksik veya hasarlı parçalarla karşılaşırsanız lütfen bizimle iletişime geçmekten çekinmeyin. Yardım etmek için buradayız!

Sehr geehrte Kunden,

Das von Ihnen gekaufte Produkt wurde vor der Lieferung einer gründlichen Qualitätskontrolle durchgezogen. Trotz dessen kann es während dem Transport zu Schäden kommen. In so einem Fall brauchen Sie nicht das komplette Produkt zurückschicken, da wir Ihnen jedes Ersatzteil zuschicken können. Bitte beachten sie dabei die auf der Aufbauanleitung verwendete Teilenummer, damit auch das richtige Teil geliefert werden kann. Bevor Sie mit dem Aufbau anfangen, kontrollieren Sie bitte alle Teile nach Schäden und Vollständigkeit. Um gründlich zu arbeiten, können Sie die Teile mit einem trockenen Tuch abwischen. Falls sie mehr wie ein Produkt gekauft haben, achten Sie darauf, die Produkte nacheinander aufzubauen, um ein Durcheinander zu verhindern. Achten Sie bitte beim transportieren der Teile darauf, diese nicht zu schleifen, sondern immer anzuheben, um Schäden zu verhindern. Bei einem längeren Transport empfehlen wir den Transport im Karton. Zur Reinigung des Produktes reicht ein feuchtes Baumwolltuch und herkömmliche Haushaltsreiniger aus. Bitte schützen Sie Ihr Produkt vor erhöhter Hitze, erhöhter Kälte und Feuchtigkeit. Nutzen Sie Ihr Produkt nur für den sinngemäßen Zweck

Wir wissen, dass Komponenten manchmal beim Transport beschädigt werden können. Sollten Ihnen fehlende oder beschädigte Teile auffallen, zögern Sie bitte nicht, uns zu kontaktieren. Wir sind hier um zu helfen!

# ATTENTION !!

Minifix is the main connection material used in products. Before starting assembly, please check the drawings below...

# DİKKAT!!

Minifix, ürünlerde kullanılan ana bağlantı malzemesidir. Montaja başlamadan önce lütfen aşağıdaki çizimleri kontrol edin...

# VORSICHT !!



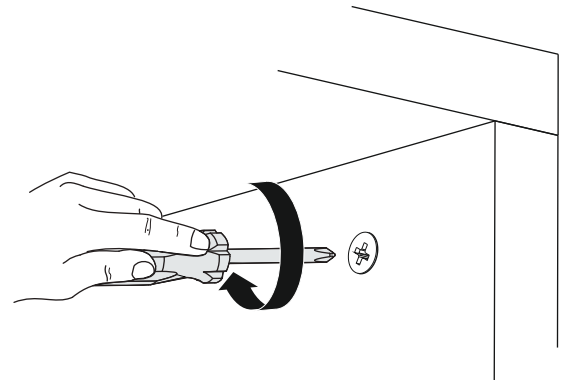
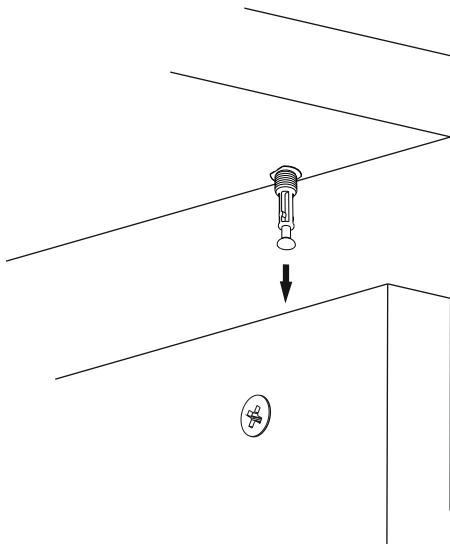
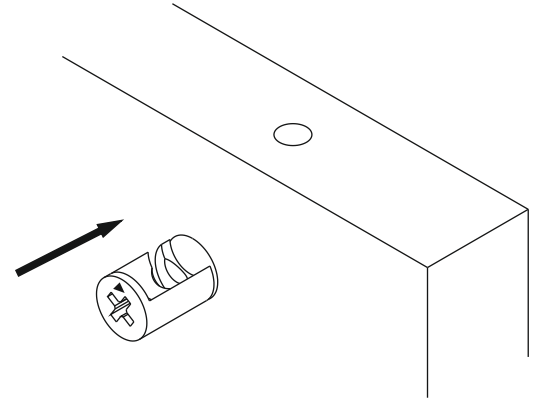
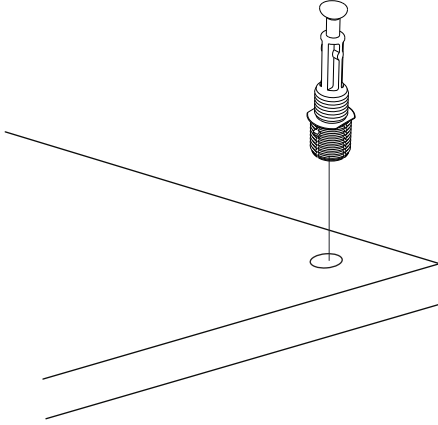
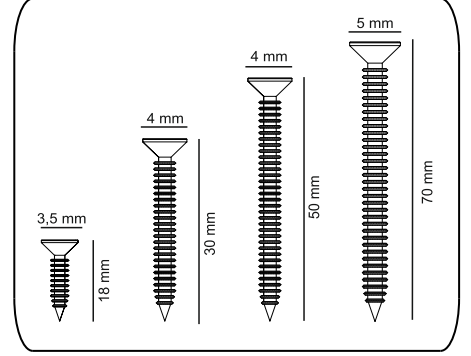
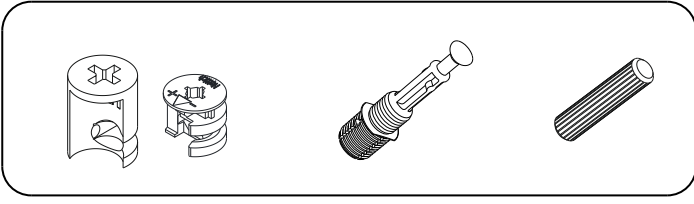



Minifiks ist das Hauptverbindungs material für diese Produkte. Bevor Sie mit dem Zusammenbau beginnen, überprüfen Sie bitte die folgenden Zeichnungen und versuchen Sie diese zu verstehen...

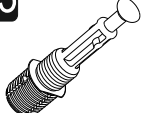

# ACCESSORY LIST / AKSESUAR LİSTESİ / ZUBEHÖRLİSTE

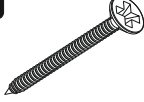
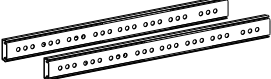
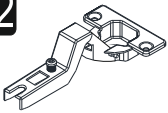
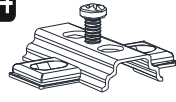

The necessary tools (not included)  
Bu modülün kurulması için gerekli araçlar.  
Erforderliche Werkzeuge zum Aufbau dieses Moduls

<b>A22</b> Minifix G18  24x	<b>A23</b> Minifix M8  24x	<b>A04</b> KVLV  20x	<b>A17</b> 4x50  4x	<b>R06</b>  300mm
<b>C02</b> SDM  4x	<b>C04</b> MA  4x	<b>A18</b> 3,5x18  44x	<b>A06</b> 18 mm SYH  28x	<b>A48</b> AC  38x

Um die gewünschte Form laut Aufbauanleitung zu erhalten, ist es wichtig, während dem Zusammenbau des Produktes händisch nachzubessern (z. B. Vor dem Festschrauben die Ecken bündlich machen)  
Kurulum talimatlarına göre istenilen şekli elde etmek için, ürünün montaj sırası önemlidir.

## GENERAL VIEW / GENEL GÖRÜNÜM / ÜBERSICHT

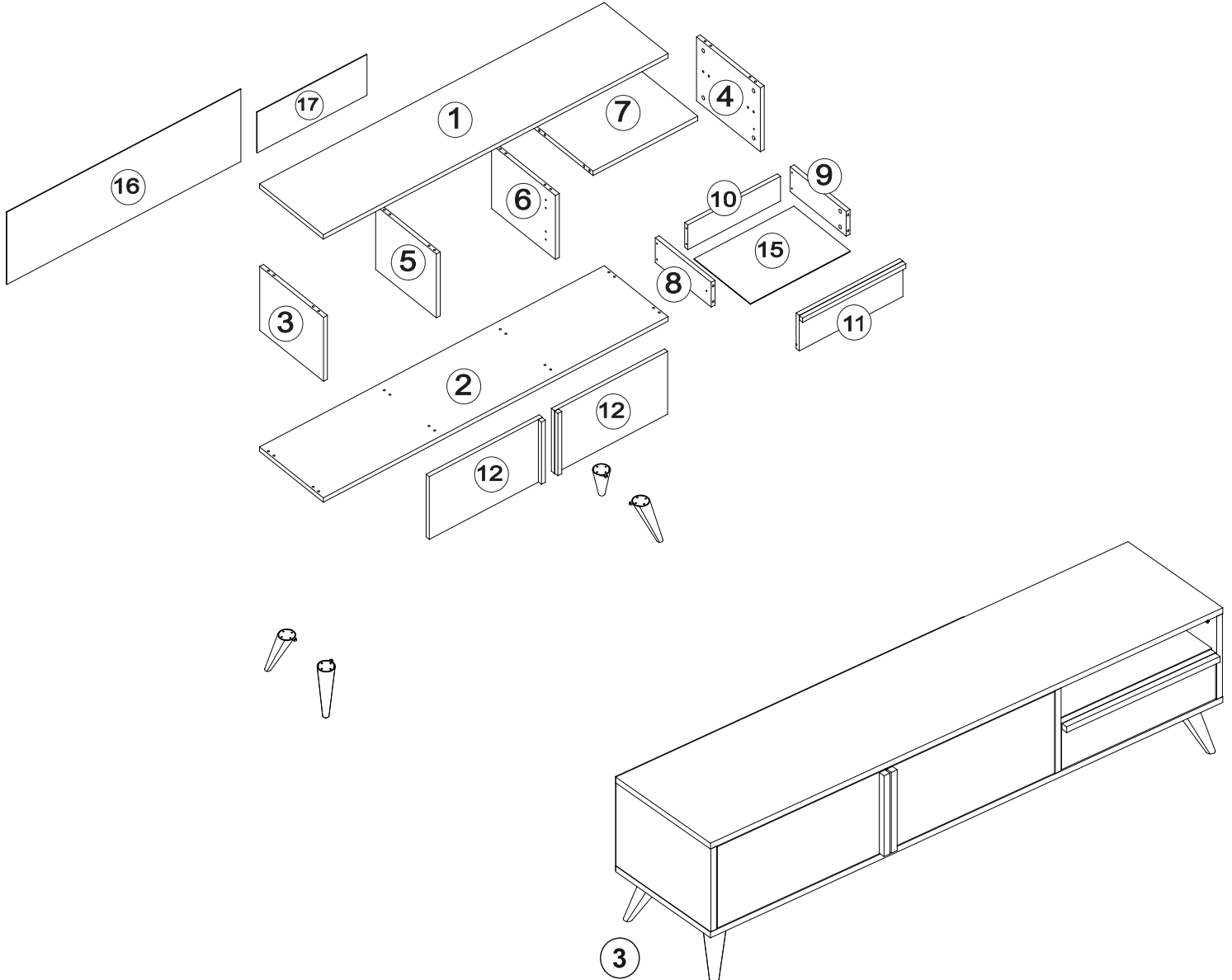



# 1

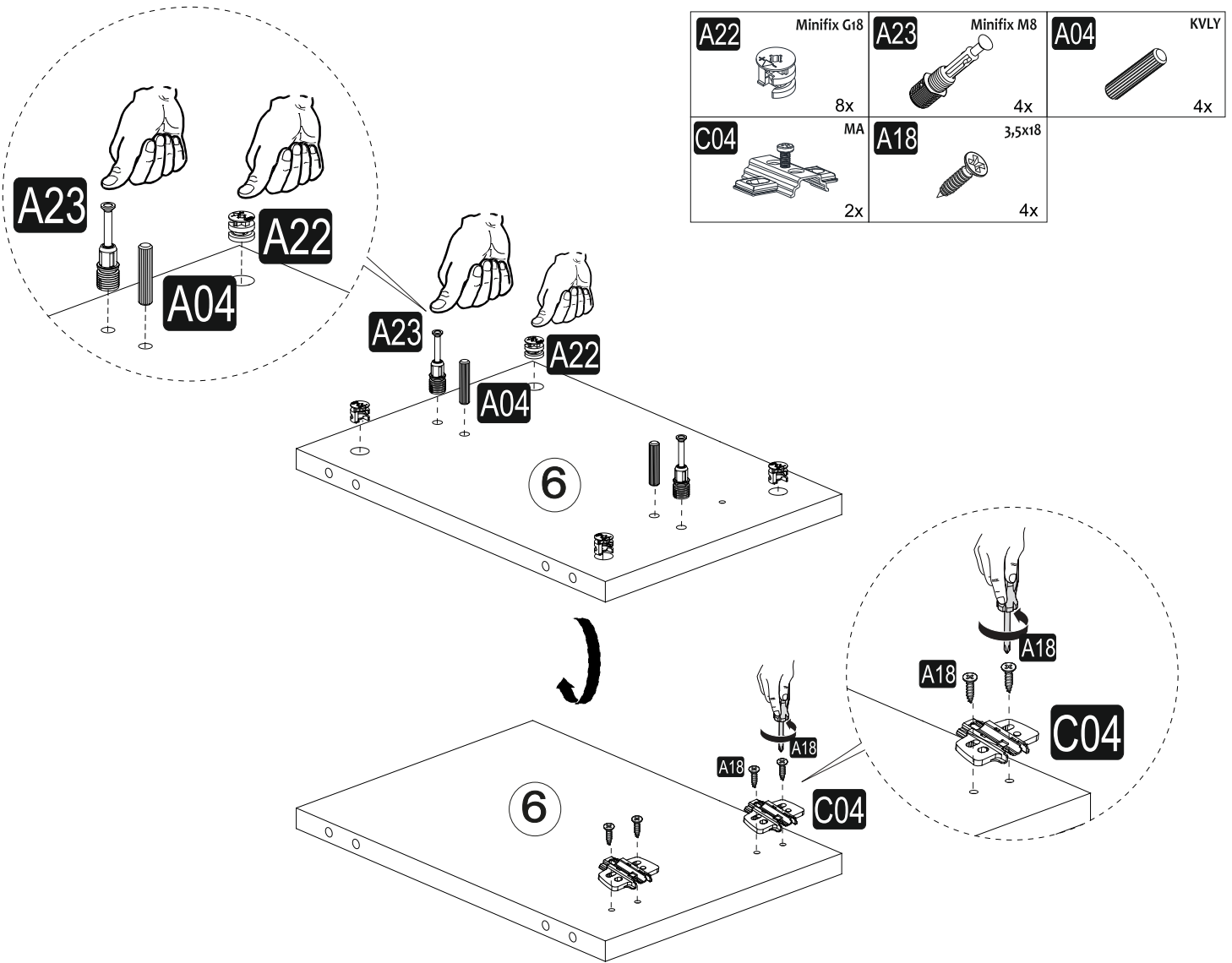

# 2

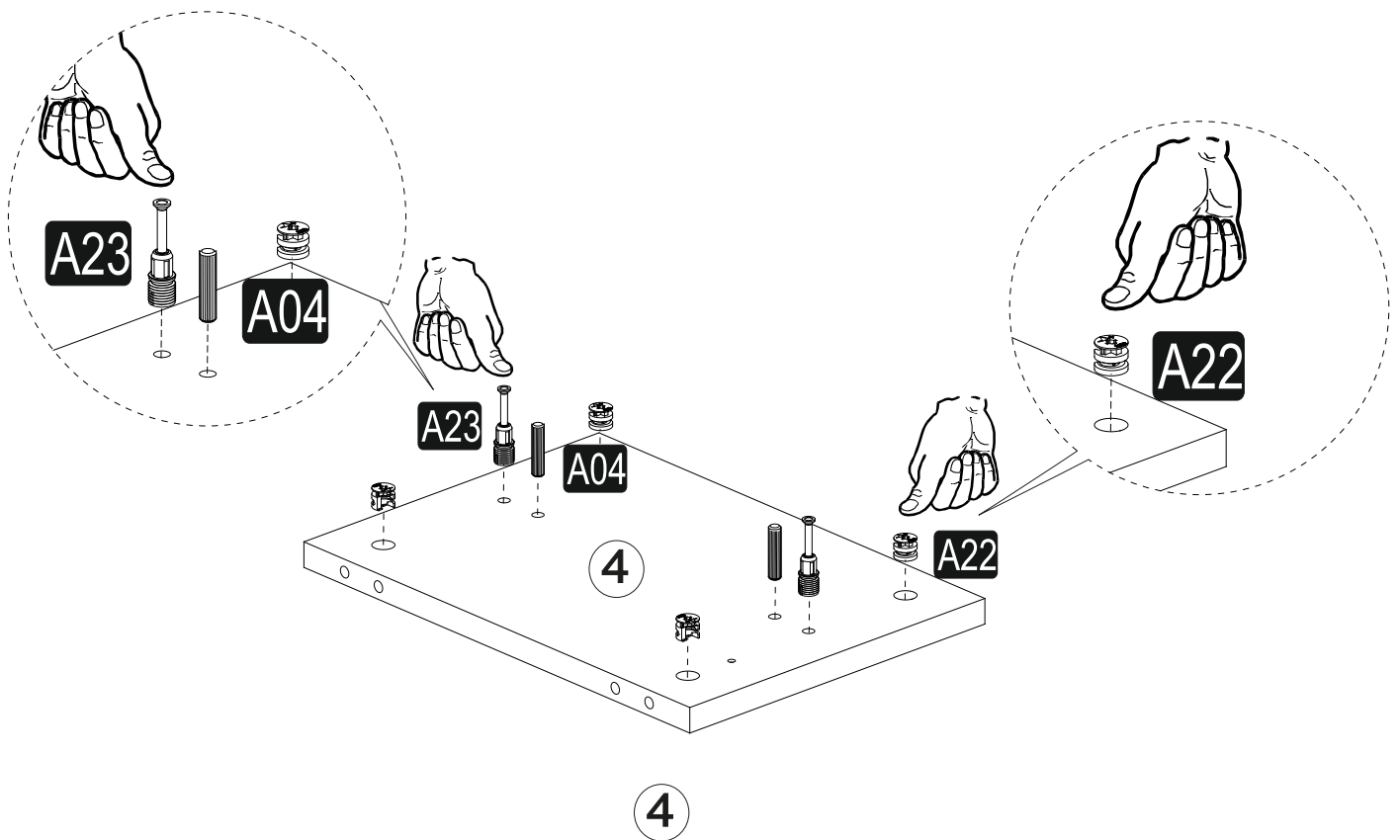

# 3

<b>A22</b> Minifix G18 4x	<b>A23</b> Minifix M8 8x	<b>A04</b> KVLY 8x
---------------------------------	--------------------------------	--------------------------

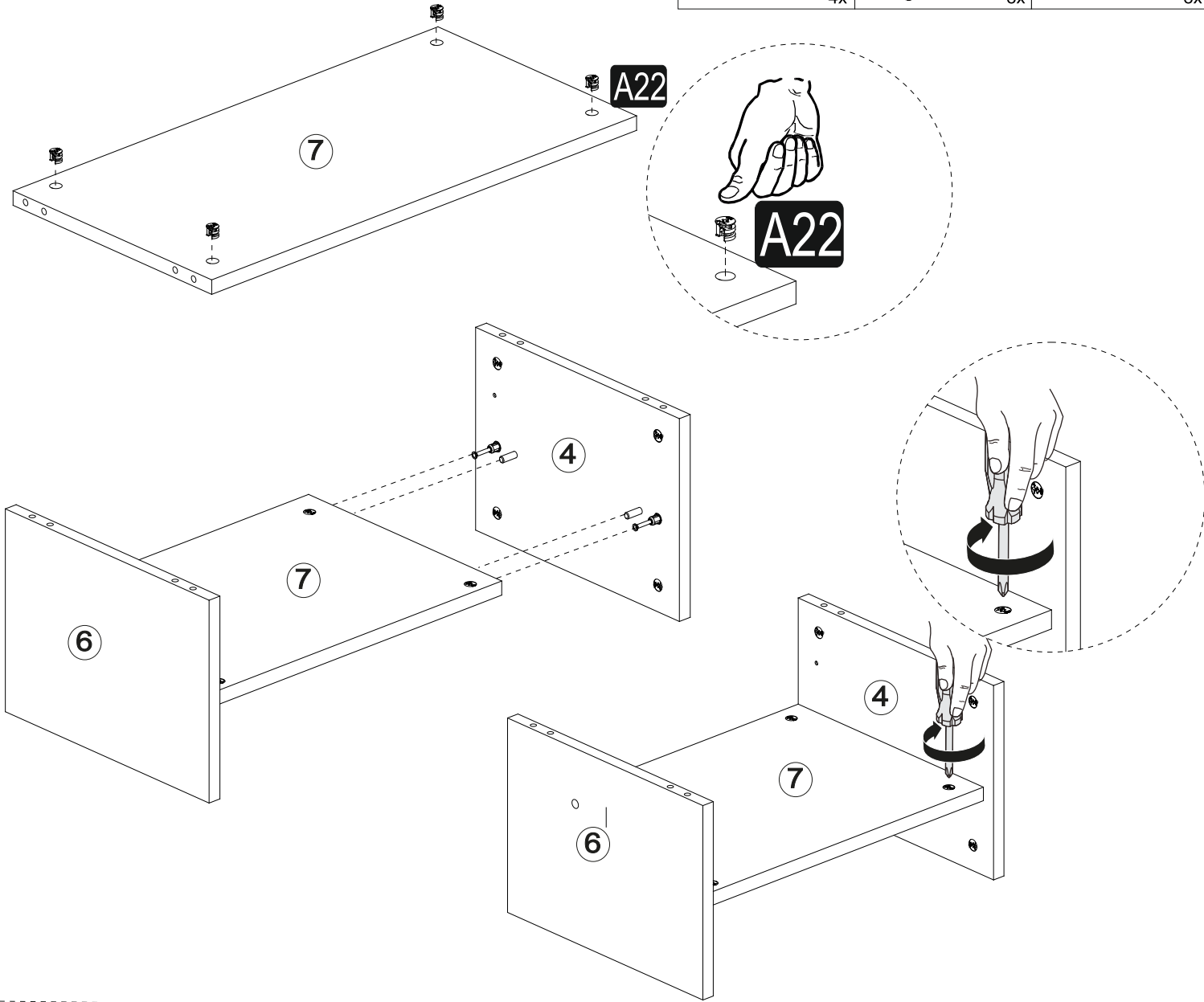

# 4

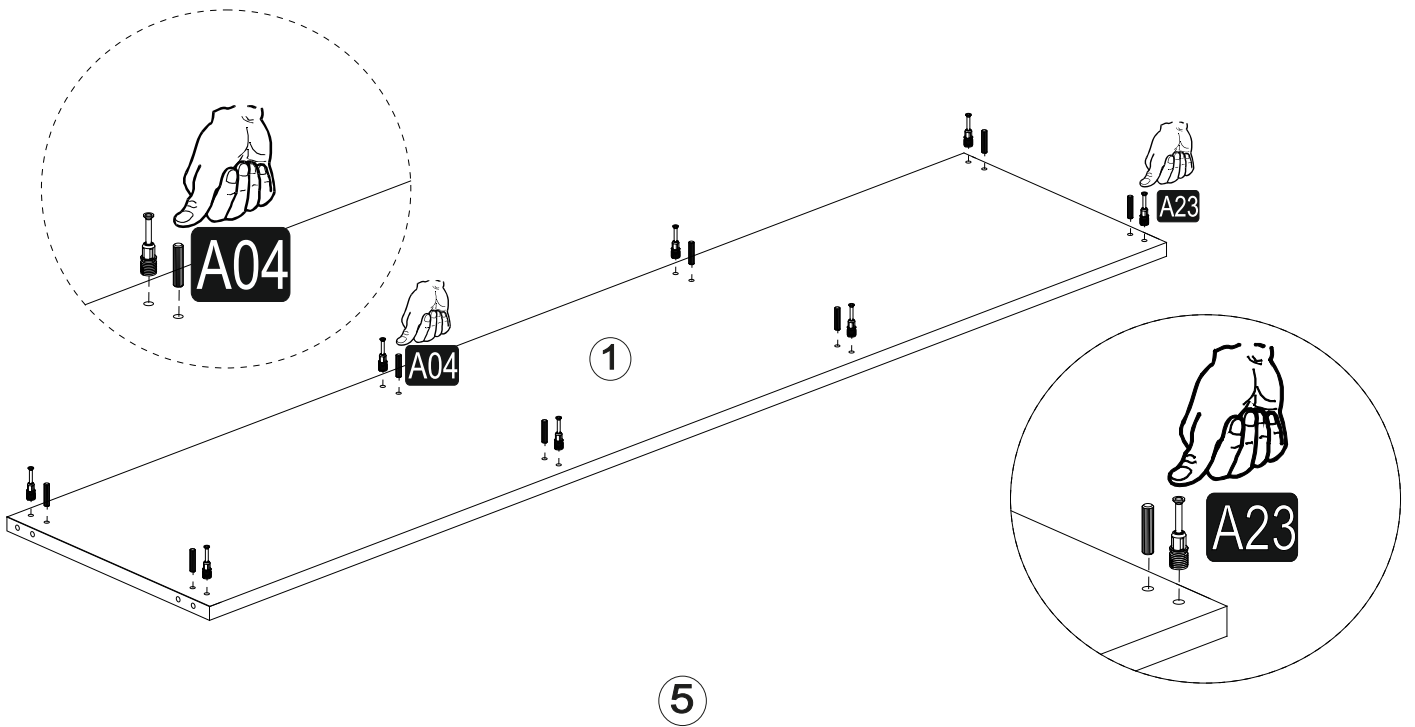

# 5

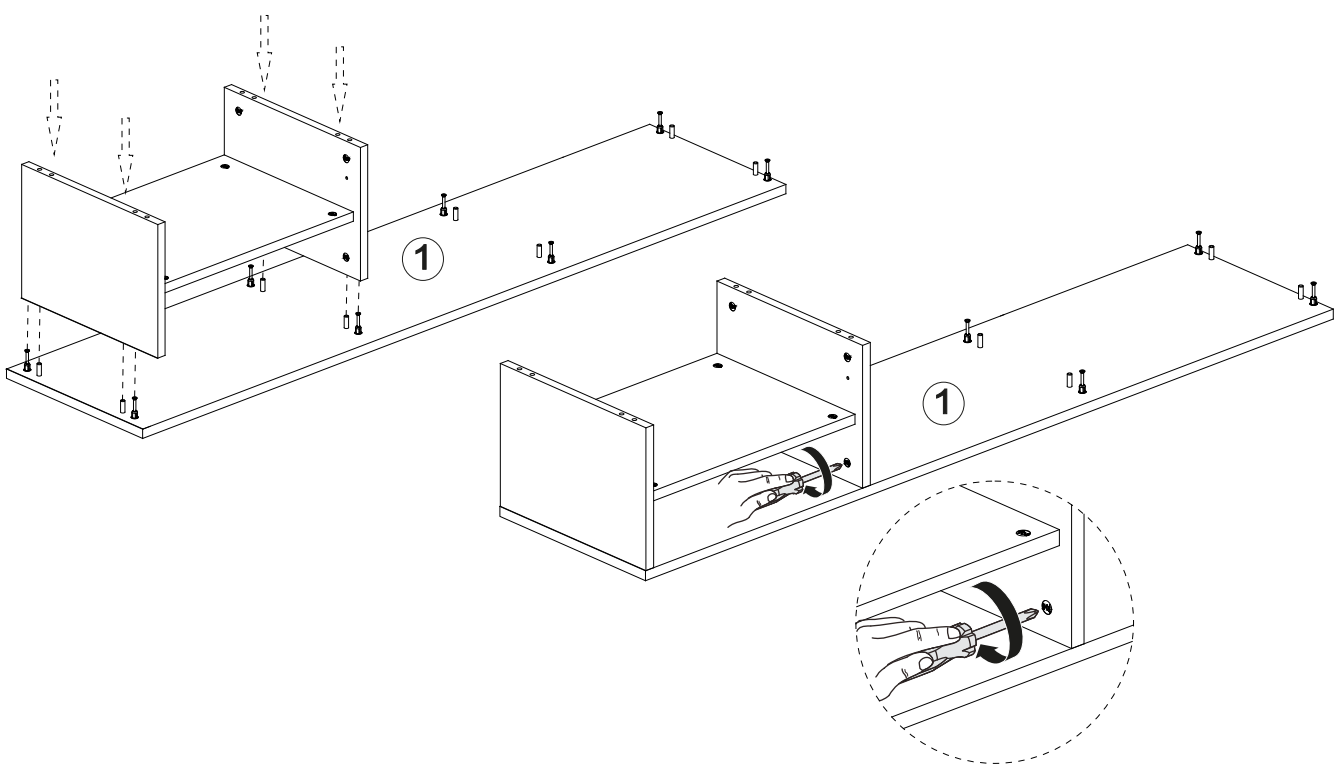

# 6

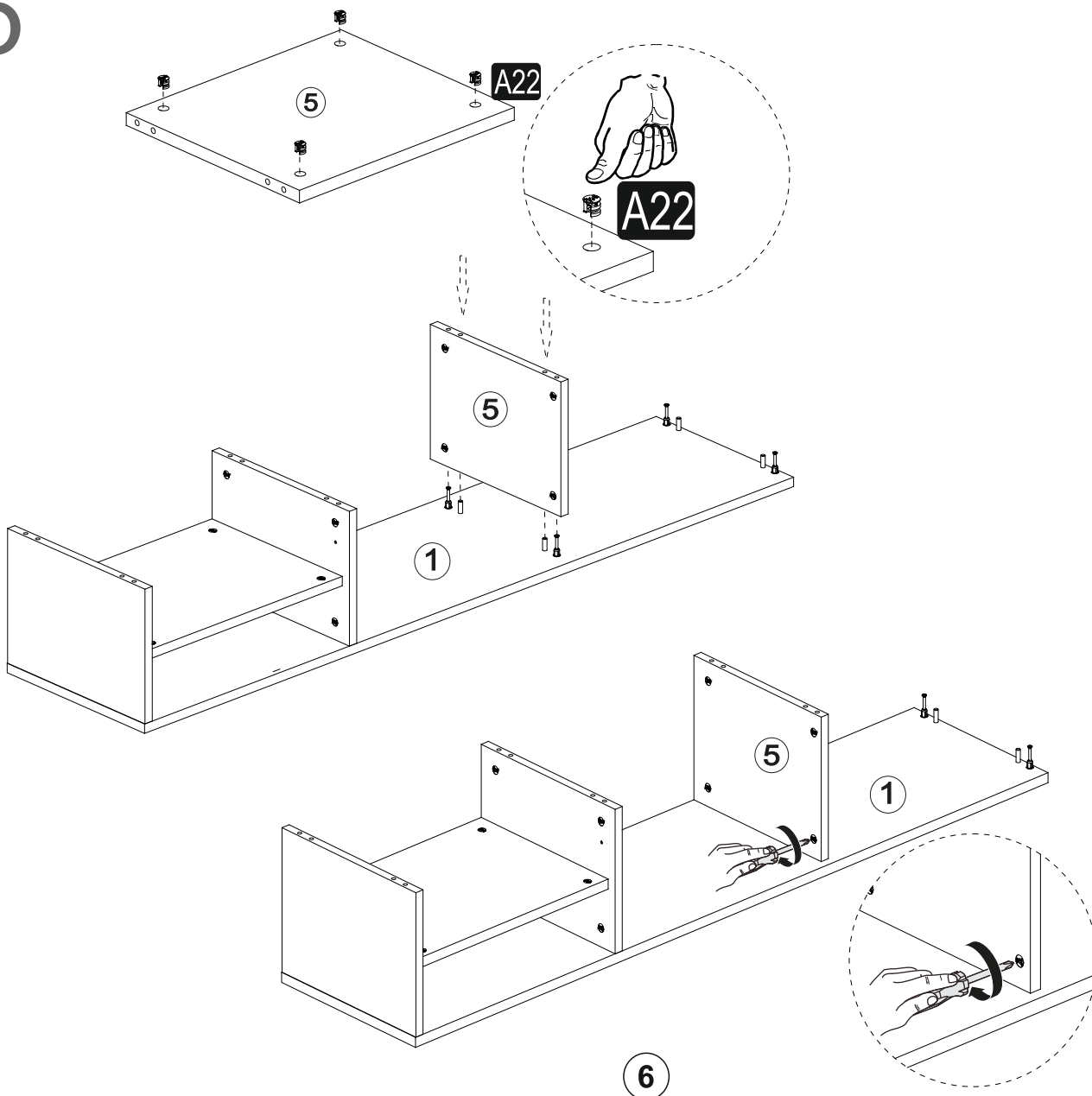

<b>A22</b>	Minifix G18
	4x

6

# 7

<b>A22</b> Minifix G18 4x	<b>C04</b> MA 2x	<b>A18</b> 3,5x18 4x
---------------------------------	------------------------	----------------------------

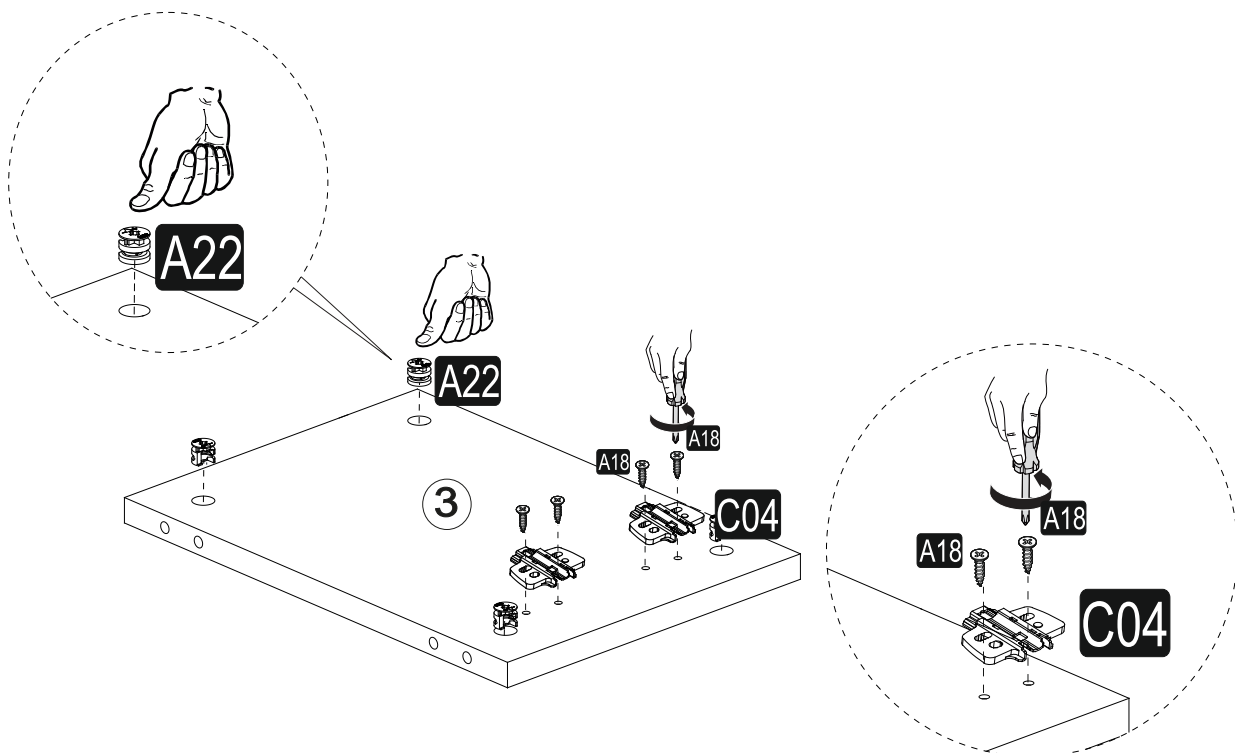

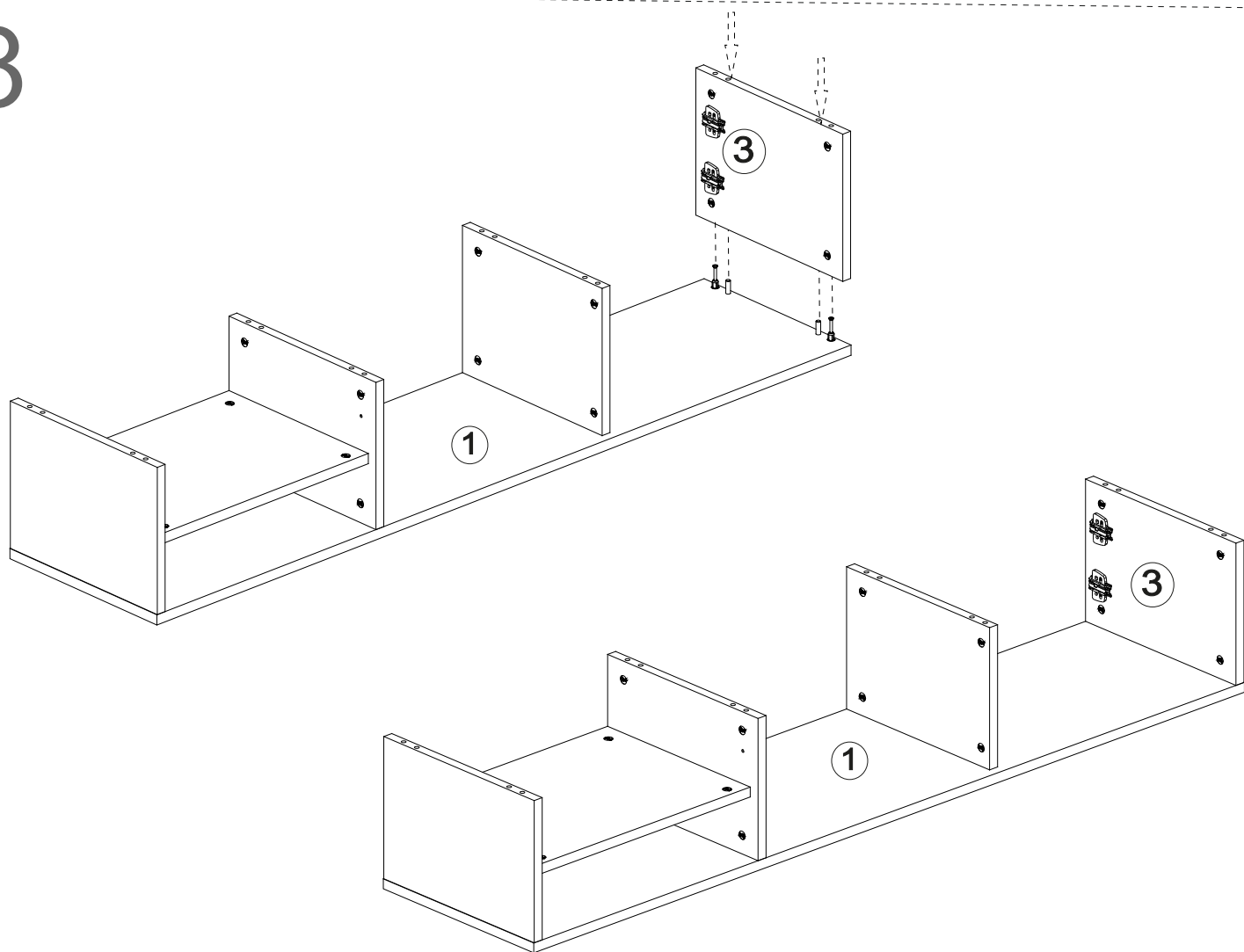

# 8

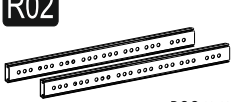

7

# 9

<b>R02</b>  300mm	<b>A18</b>  3,5x18 8x
---	--

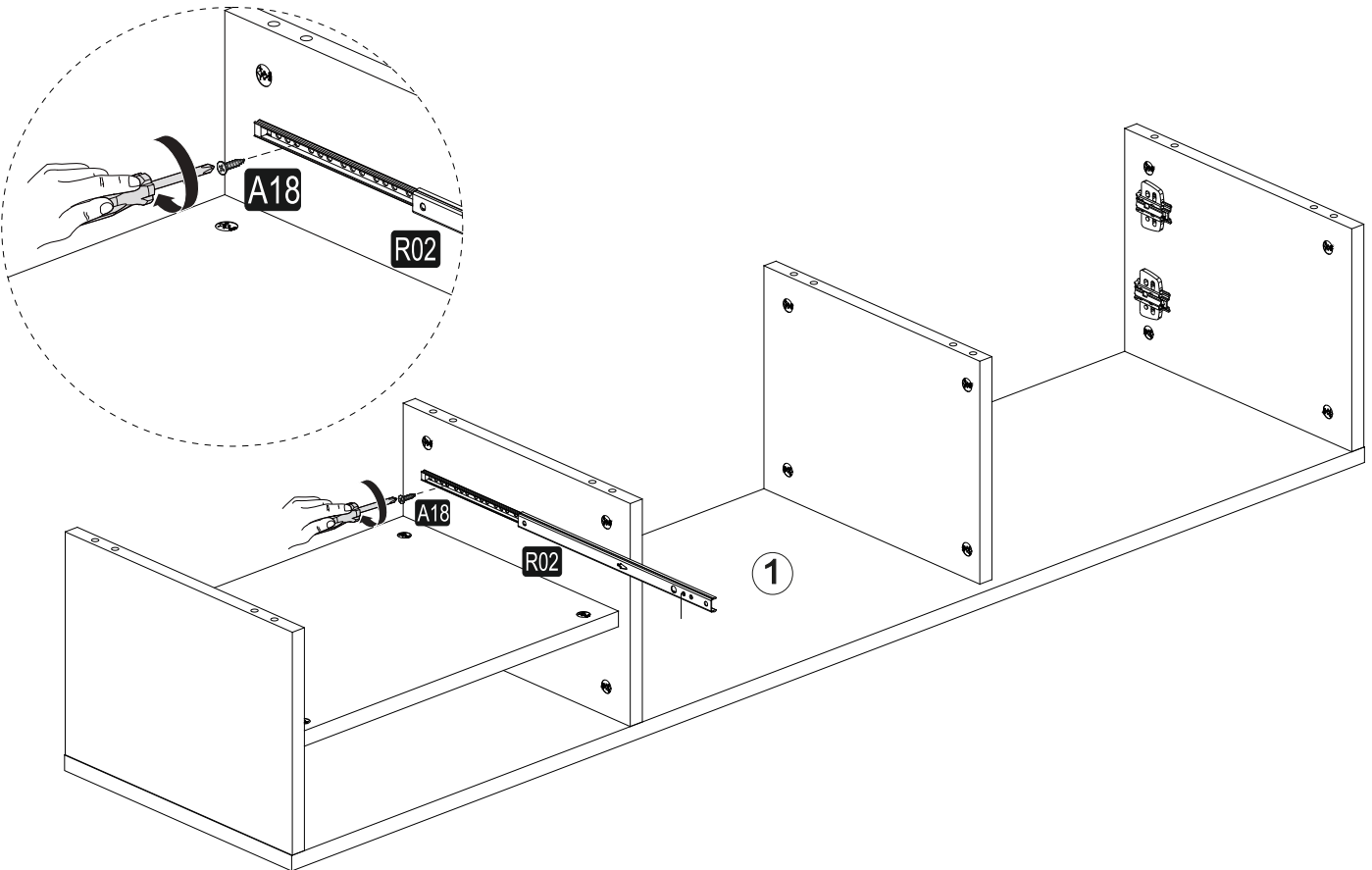

# 10

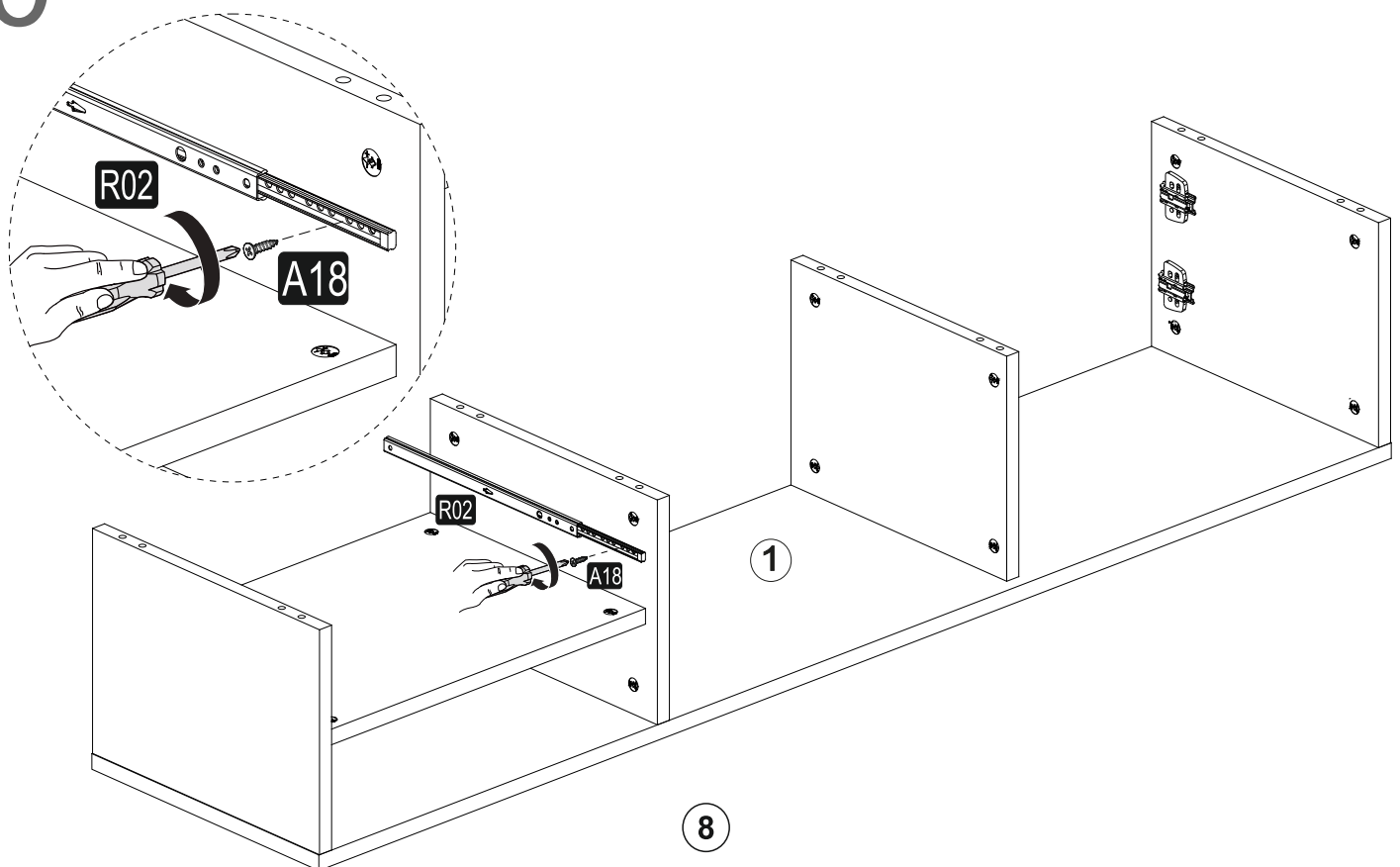

# 11

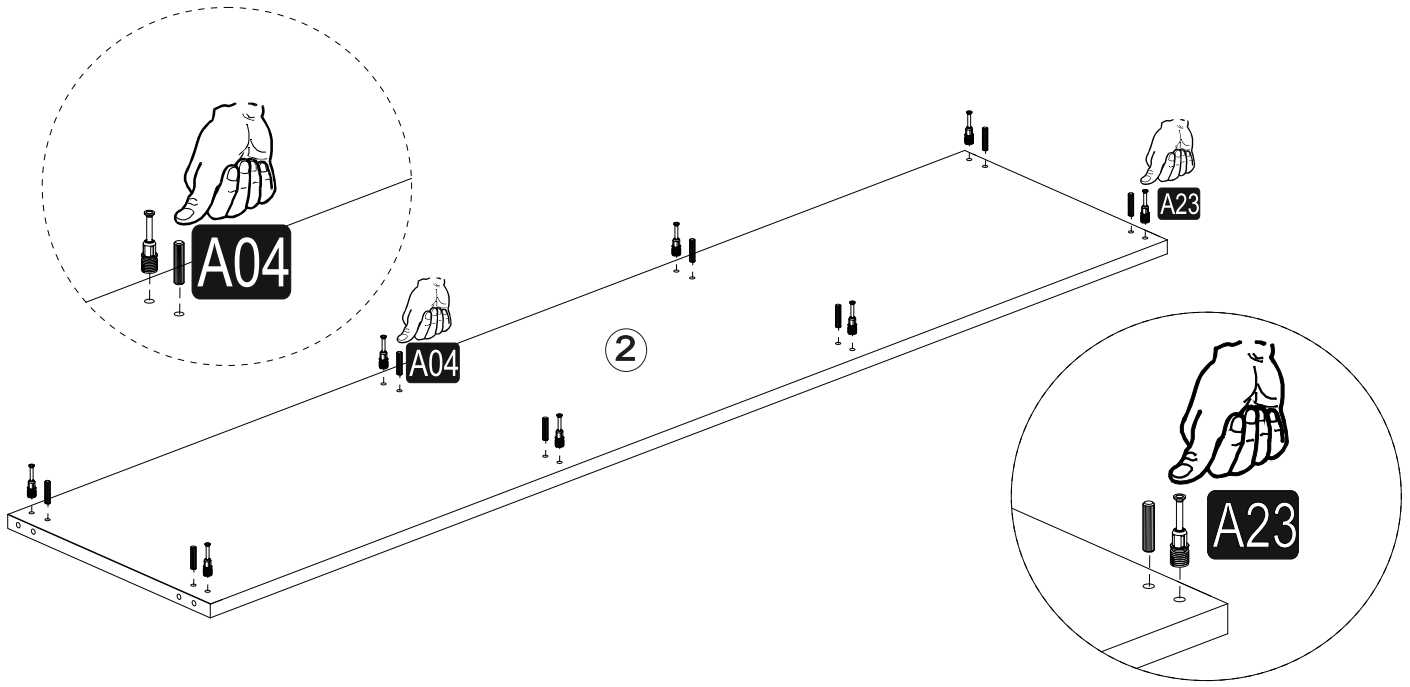

# 12

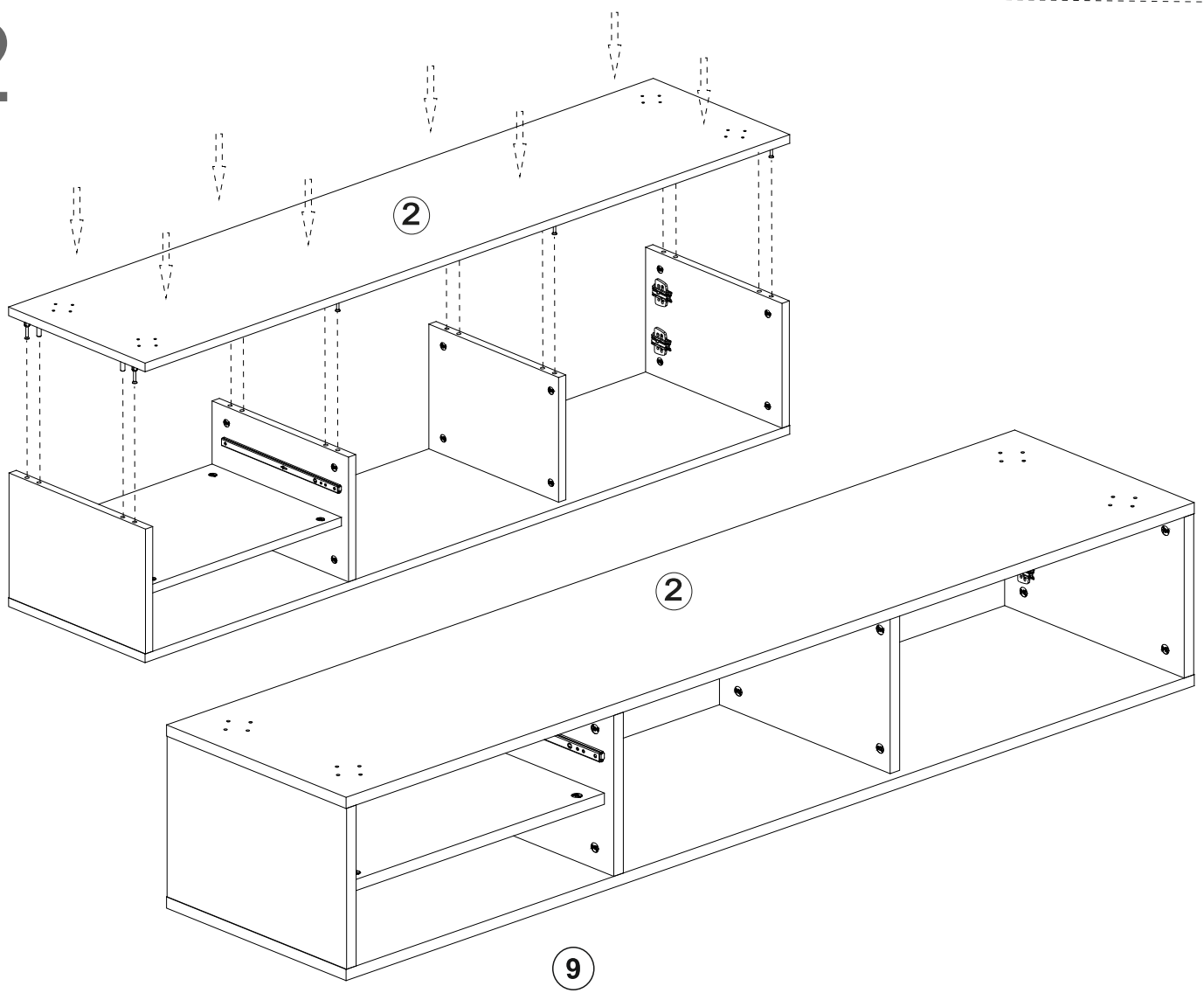

# 13

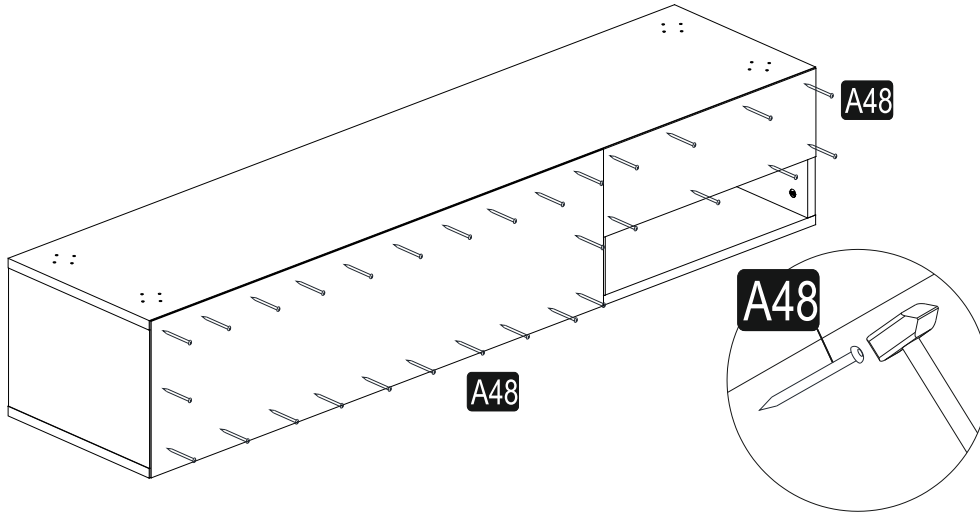
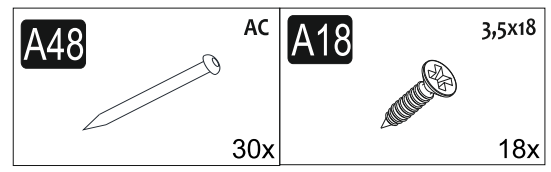

# 14

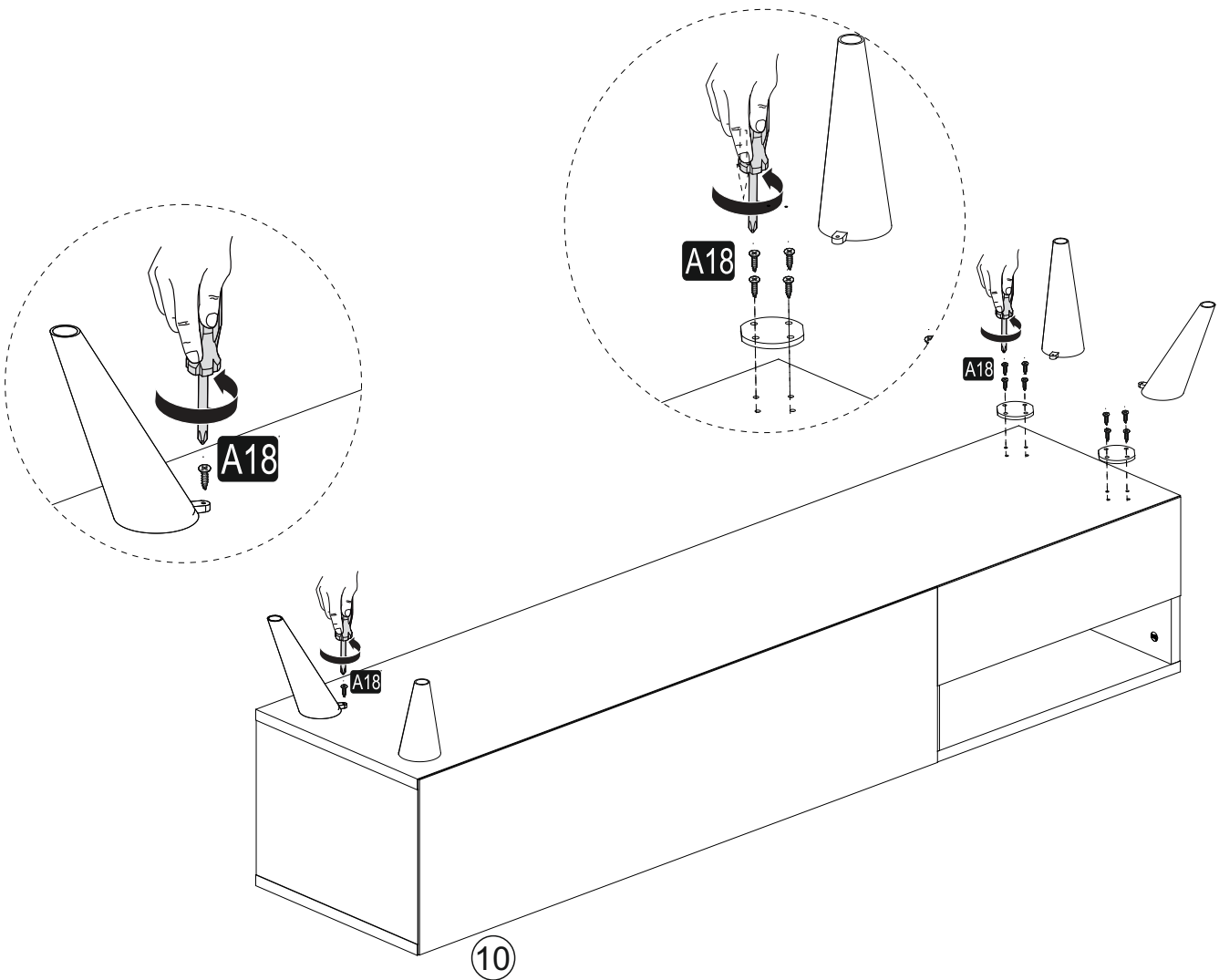

# 15

<b>A22</b> Minifix G18 4x	<b>A23</b> Minifix M8 4x
<b>A17</b> 4x50 4x	<b>A48</b> AC 8x

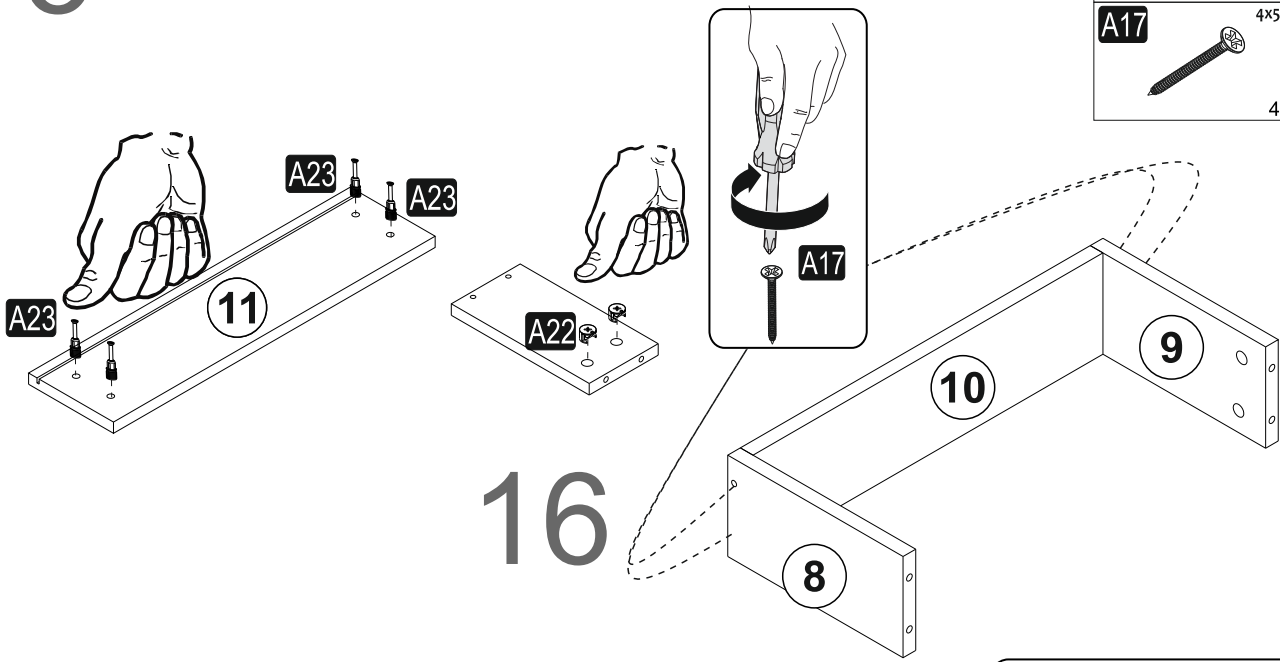

# 16

# 17

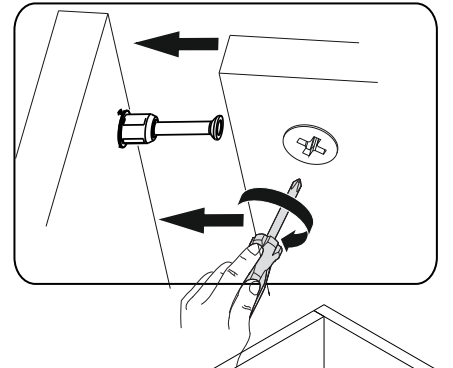

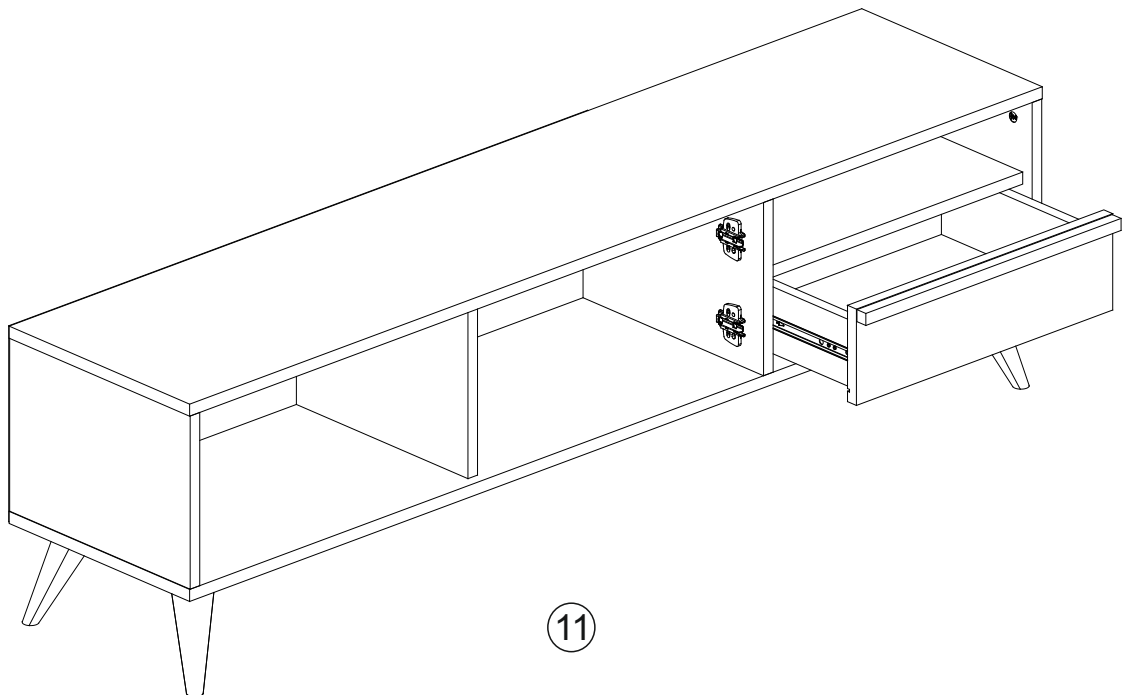
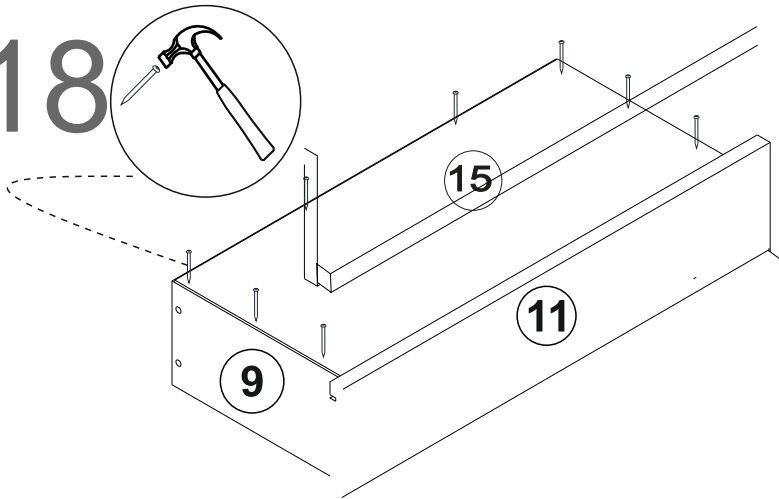

# 18



11

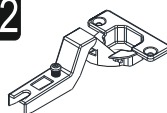

<b>C02</b>	SDM	<b>A18</b>	3,5x18
			
4x		8x	

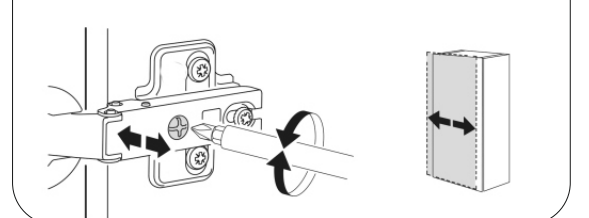
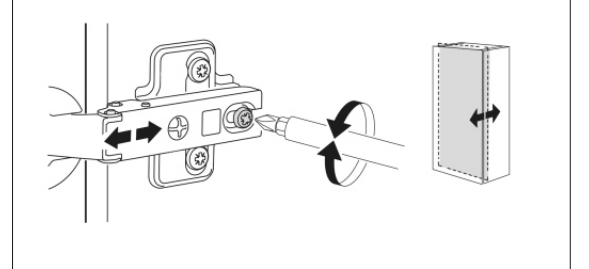
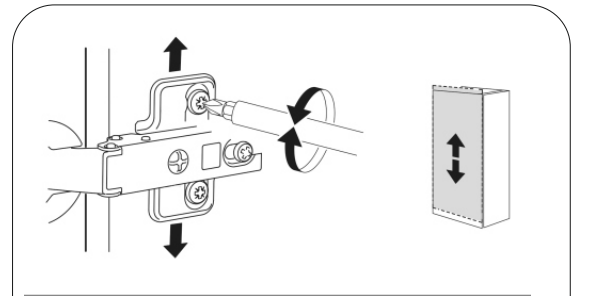
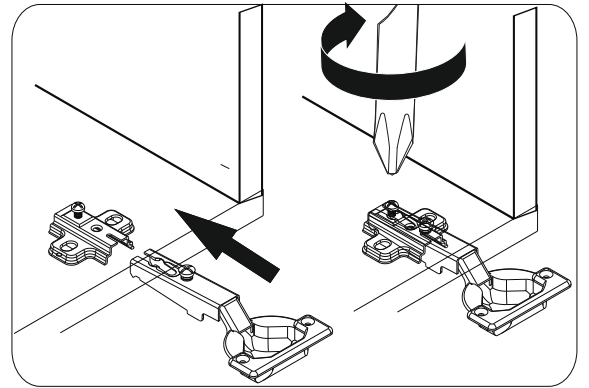
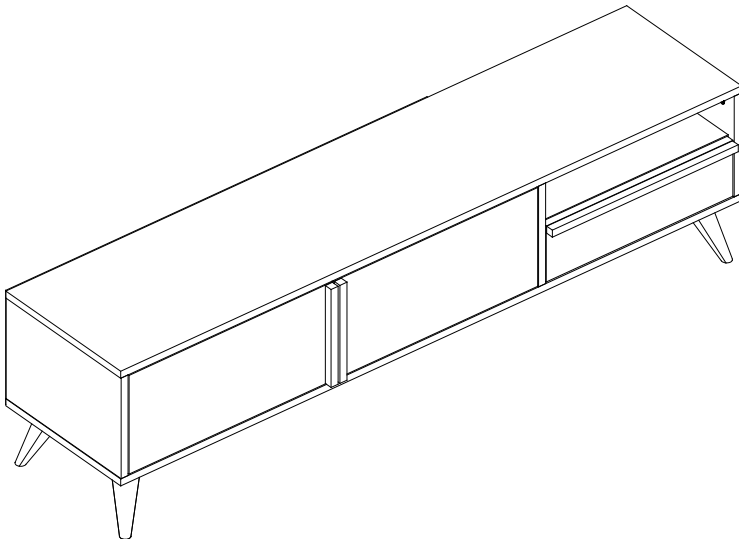
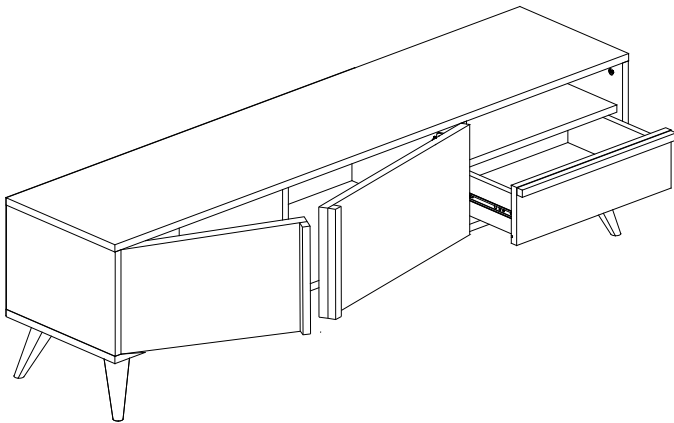
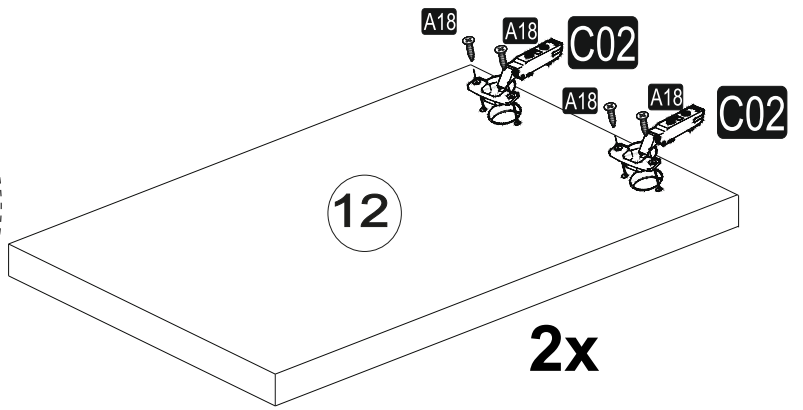
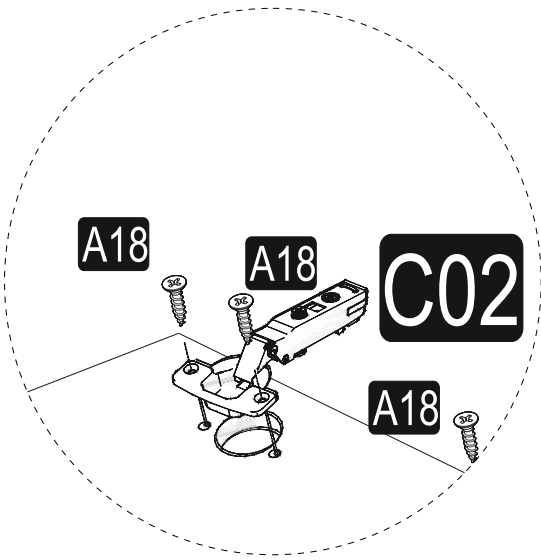

# T0018

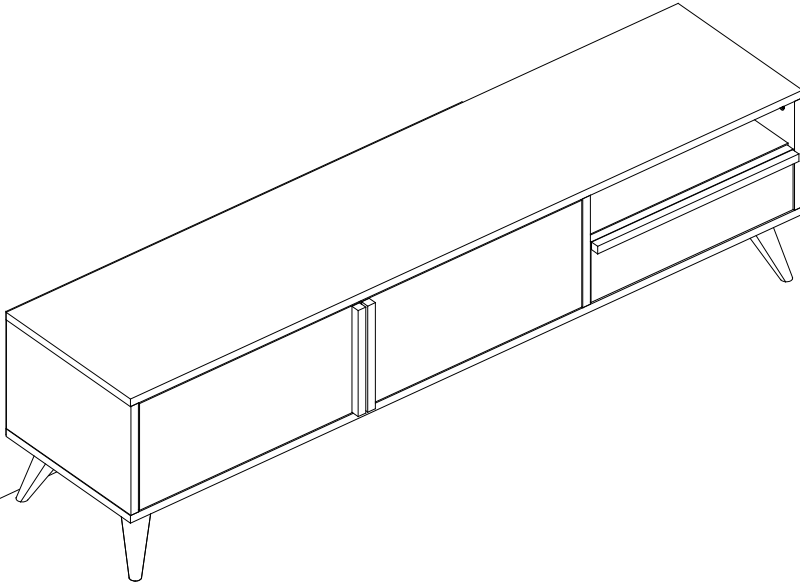

Have you seen our other products ?  
Diğer ürünlerimizi gördünüz mü ?  
Haben Sie schon unsere anderen Produkte gesehen ?