

yukon tv ünitesi

furmet

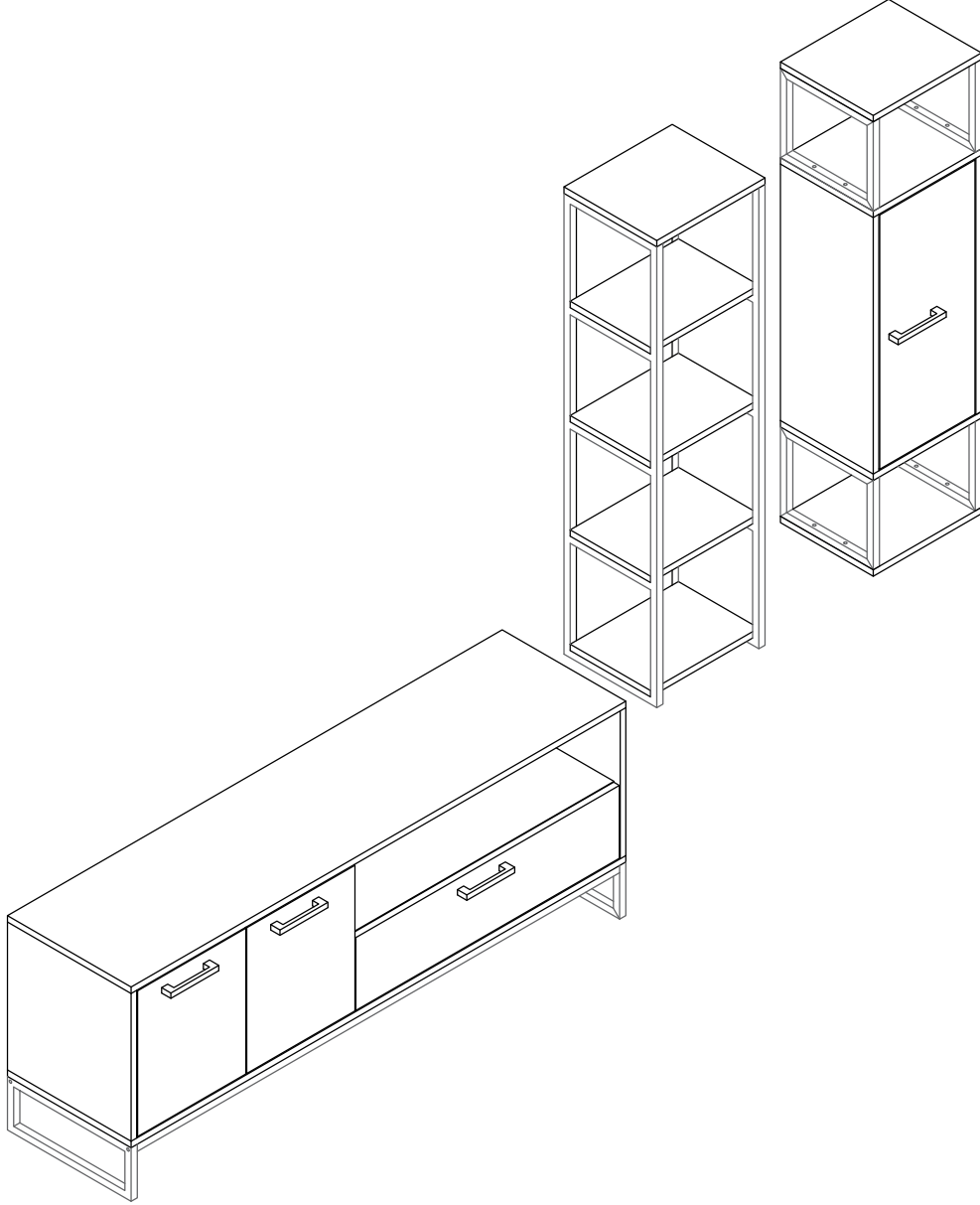

MOYEN-MEDIUM
MITTEL-MEDIO

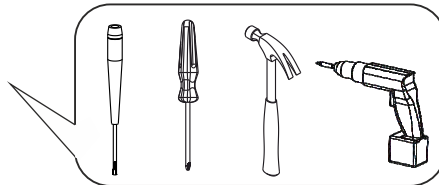
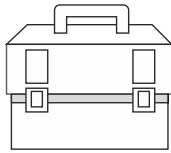
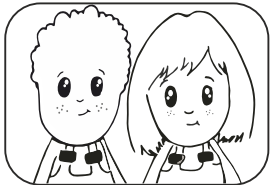

TR/ Eğer ürününüzle ilgili yardıma ihtiyacınız olursa email: info@furmet.com.tr

UK/ If you need information about your product, email: info@furmet.com.tr

GE/ Wenn Sie Fragen zu Ihrem Produkt, email: info@furmet.com.tr

FR/ Si vous avez des questions sur votre produit, email: info@furmet.com.tr

ES/ Si tiene alguna pregunta acerca de su producto, email: info@furmet.com.tr

PT/ Se você tiver dúvidas sobre o seu produto, email: info@furmet.com.tr

SE/ Om du har frågor om din produkt, email: info@furmet.com.tr

NW/ Hvis du trenger informasjon om produktet, email: info@furmet.com.tr

IT/ Se hai delle domande sul tuo articolo, ecco la mail via nuestro website

PL/ Jeśli mają Państwo pytania dotyczące produktu, email: info@furmet.com.tr

RU/ Если Вам необходима дополнительная информация о товаре, свяжитесь с нами по email: info@furmet.com.tr

hey you!

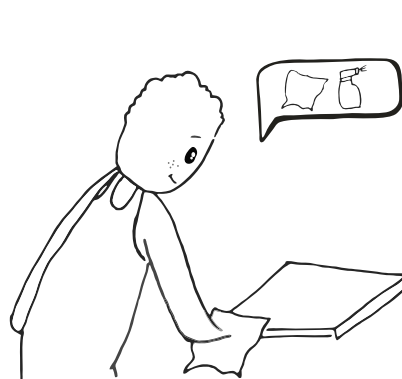
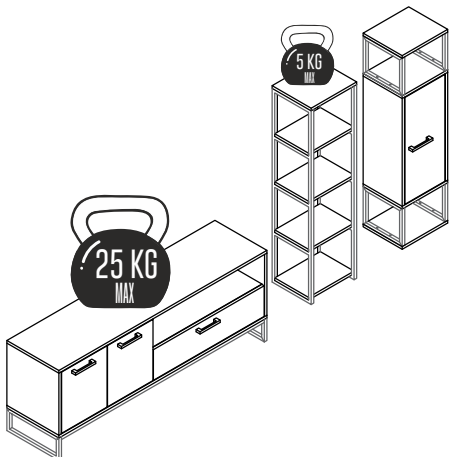
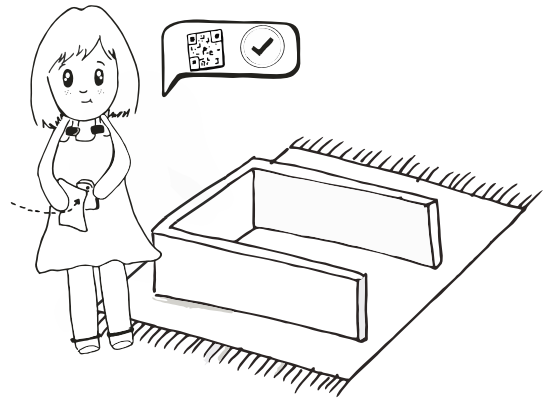
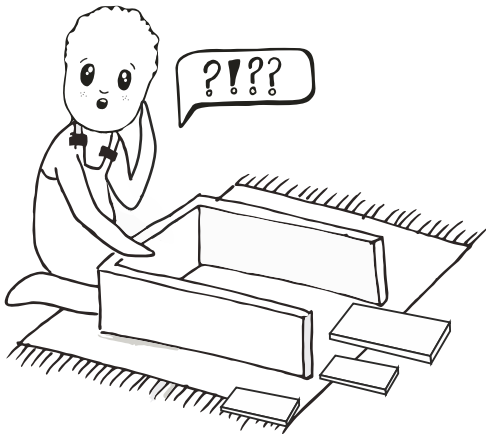
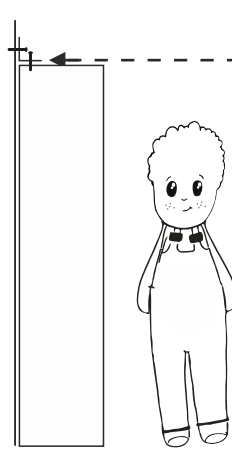
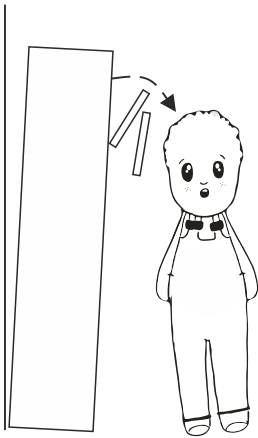
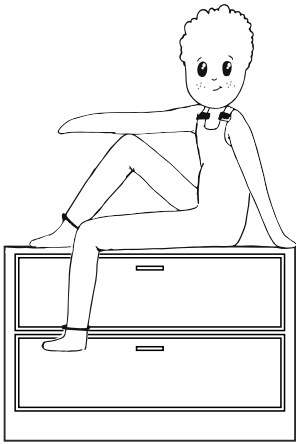

PS: Clean only with a damp cloth.
NOT: Yalnızca nemli bir bezle temizleyiniz.

caution!

Minifix is the main connection material used in products. Before starting assembly, please check the drawings below.

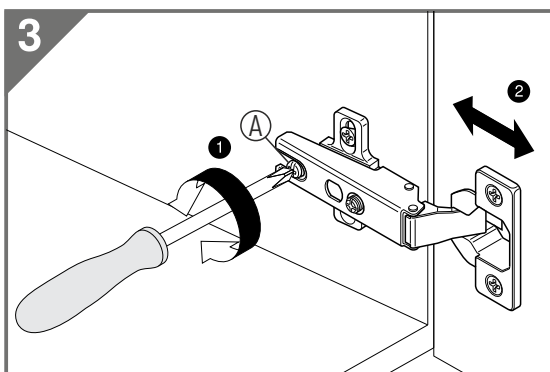
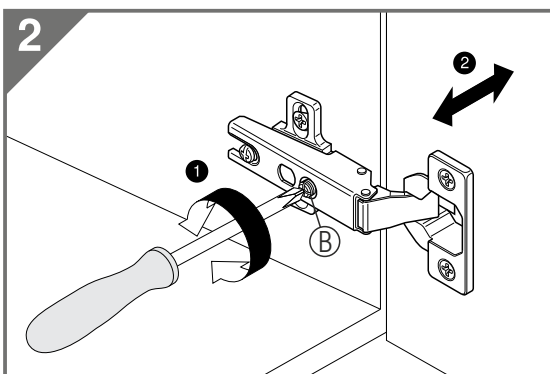
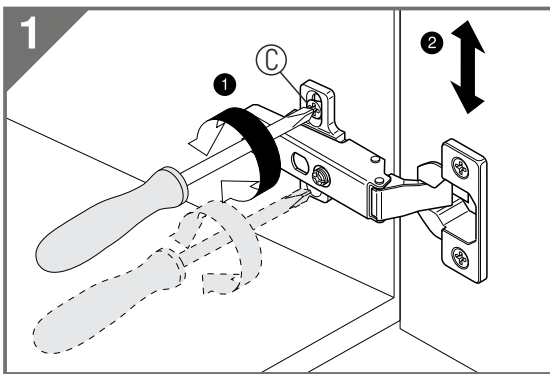
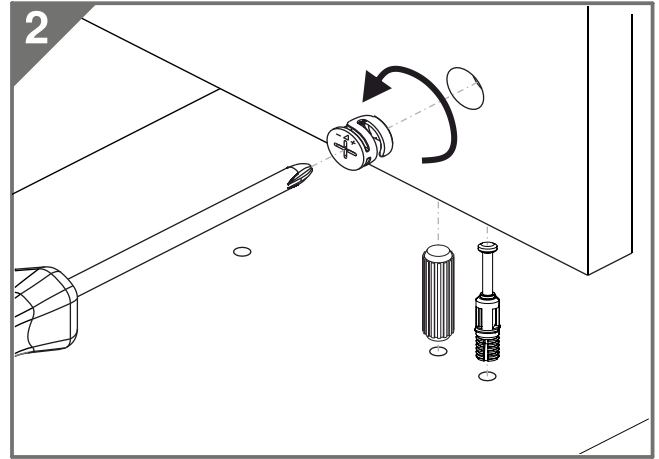
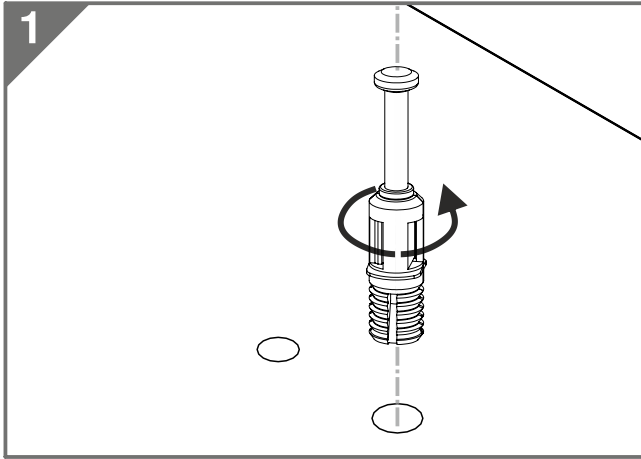

Height adjustment: Loosen screw 'C', adjust height, retighten screw 'C'.

Depth adjustment: Loosen fixing 'A', push hinge arm forwards or backwards, retighten screw 'A', fix screw 'B' with a 1/4- turn in clock-wise direction.

Side adjustment: Loosen fixing screw 'A', adjust gap with screw 'B' and retighten screw 'A'.

TOOLBOX

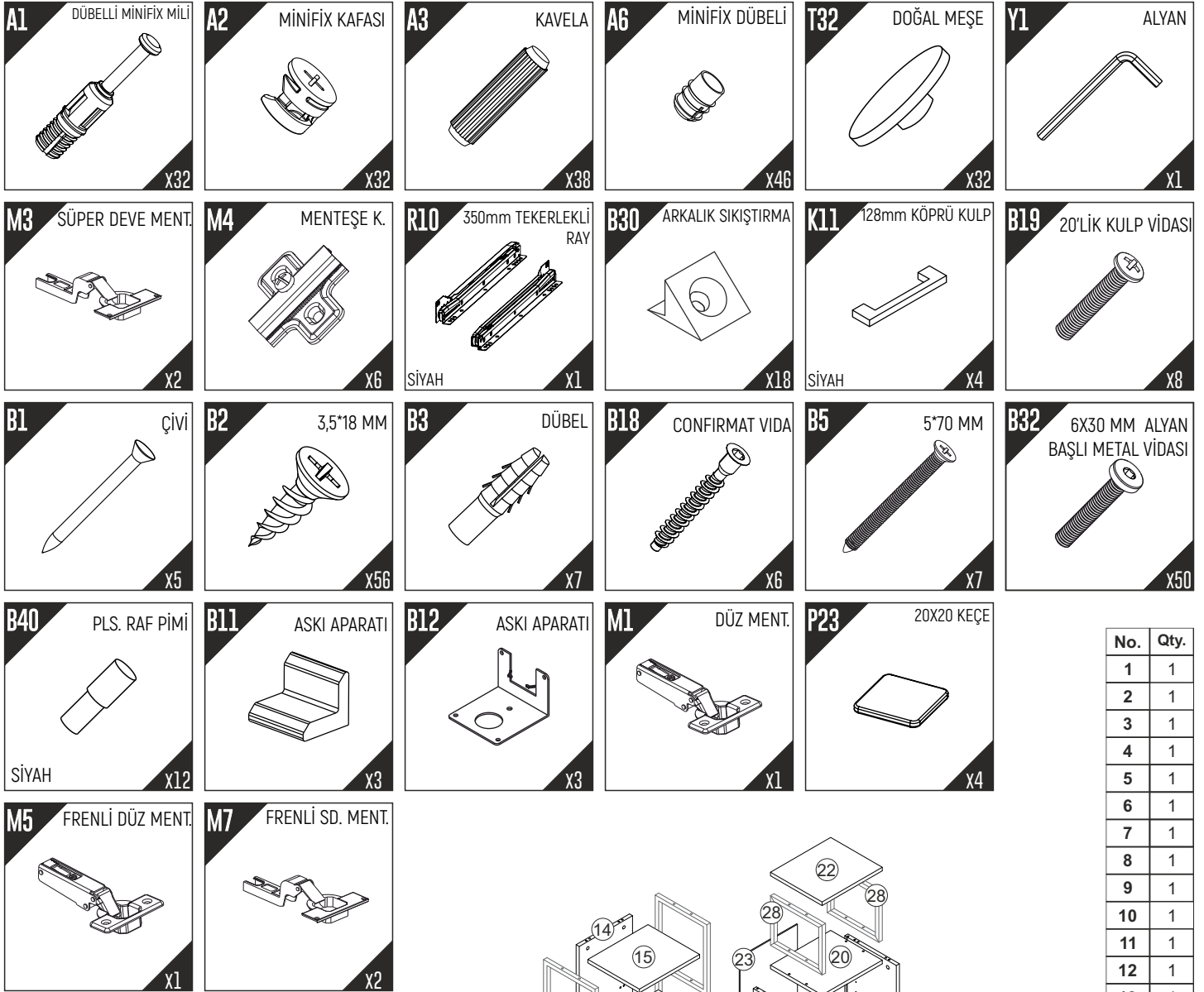

No.	Qty.
1	1
2	1
3	1
4	1
5	1
6	1
7	1
8	1
9	1
10	1
11	1
12	1
13	1
14	1
15	1
16	4
17	1
18	1
19	1
20	2
21	2
22	2
23	1
24	1
25	1
26	2
27	2
28	4
29	2

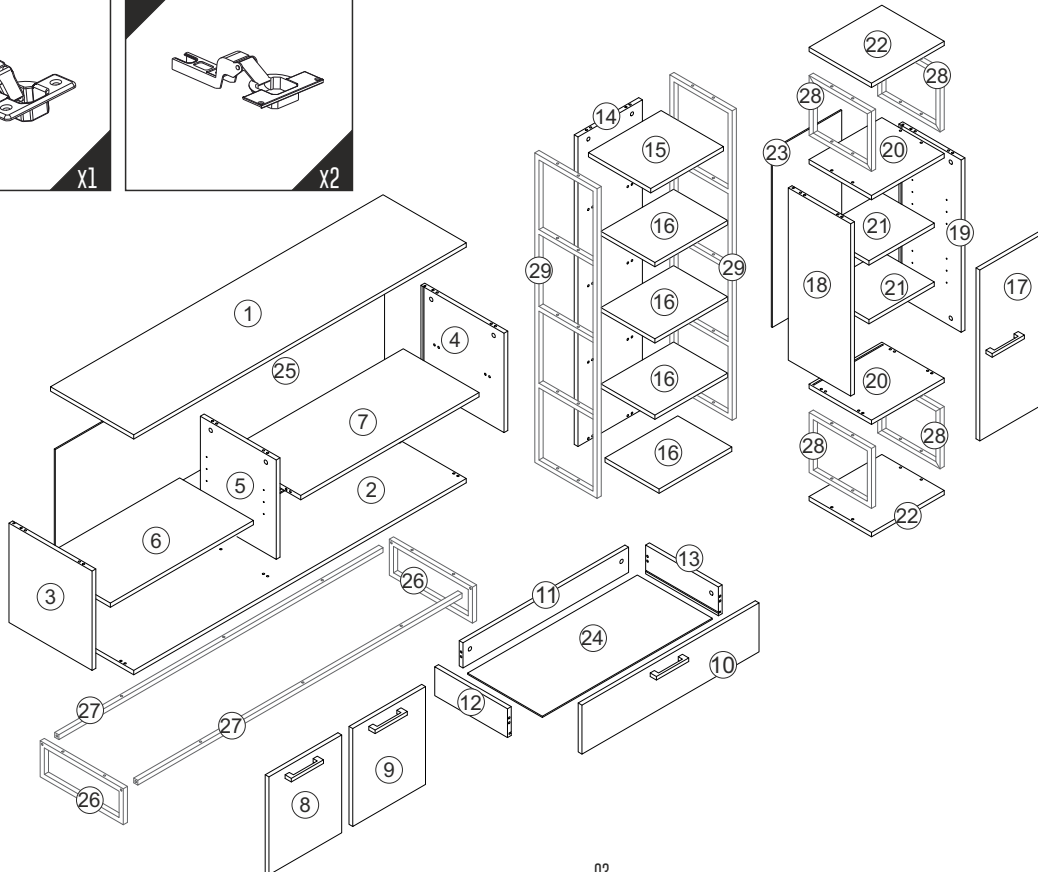

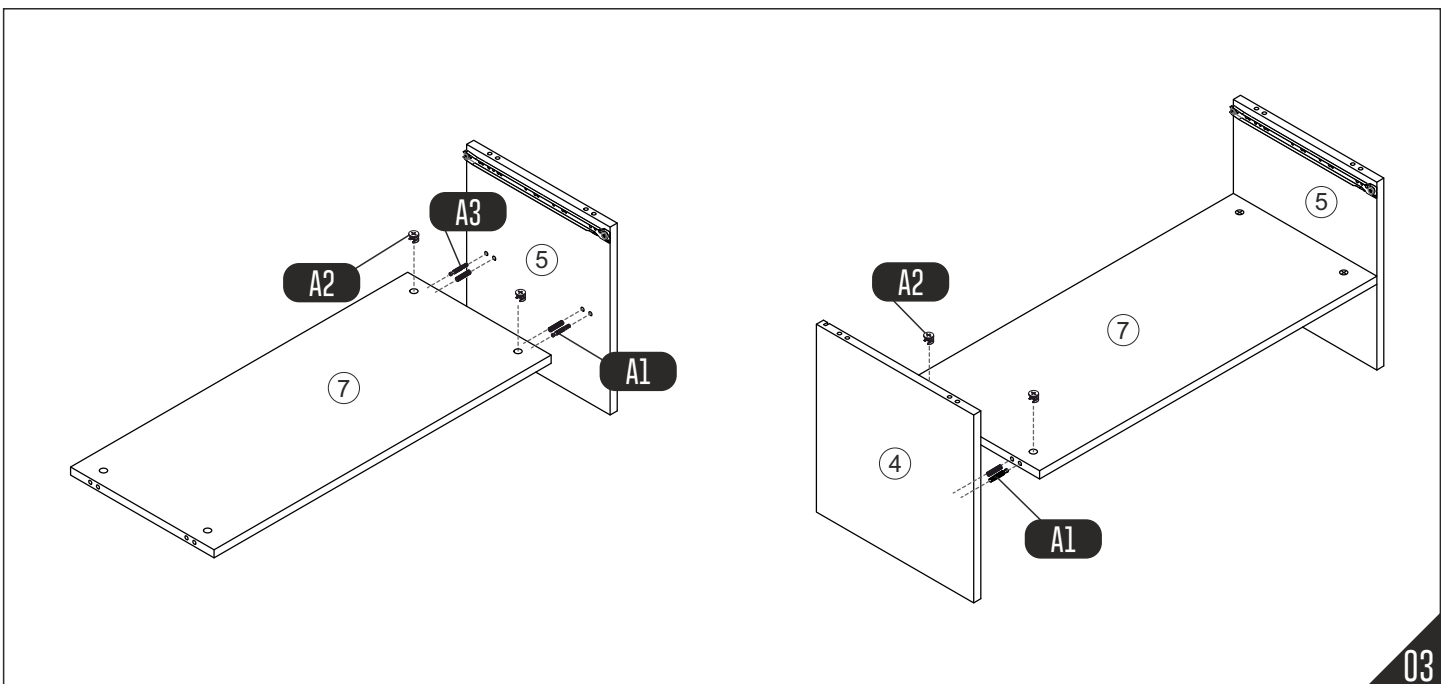
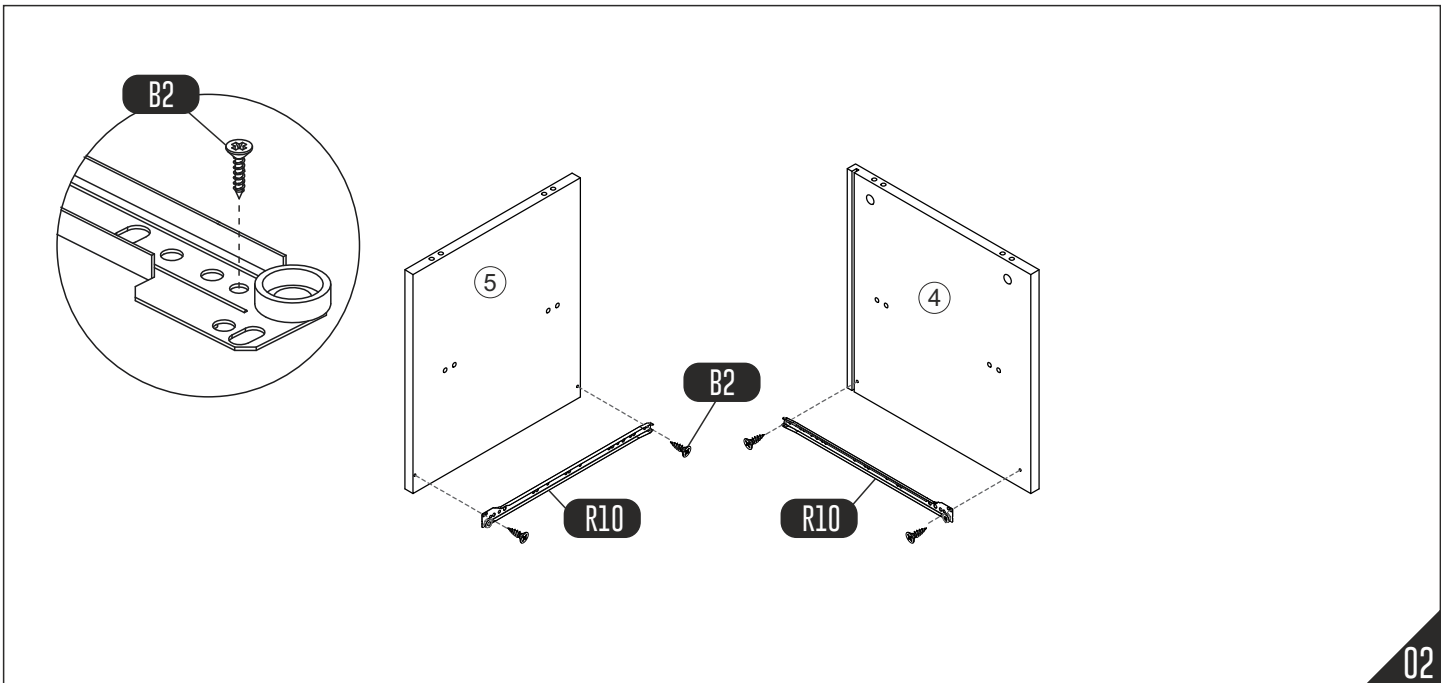
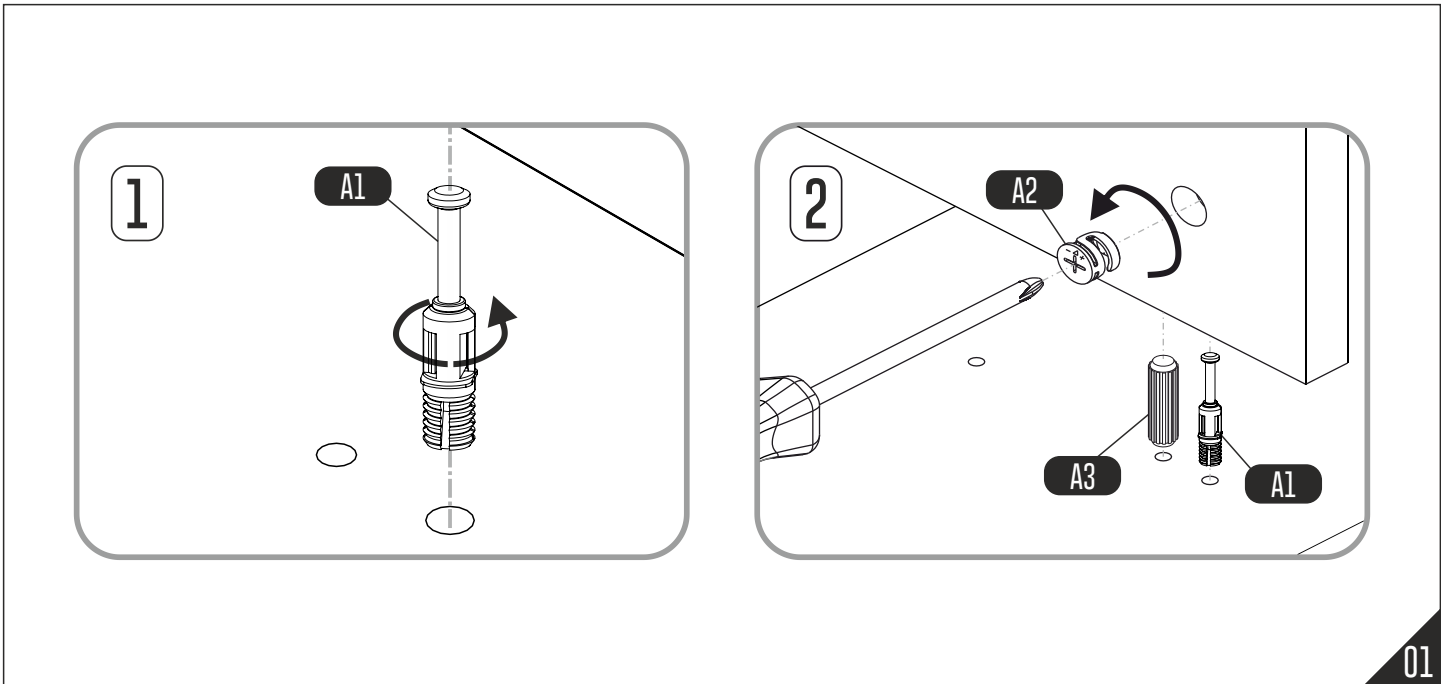

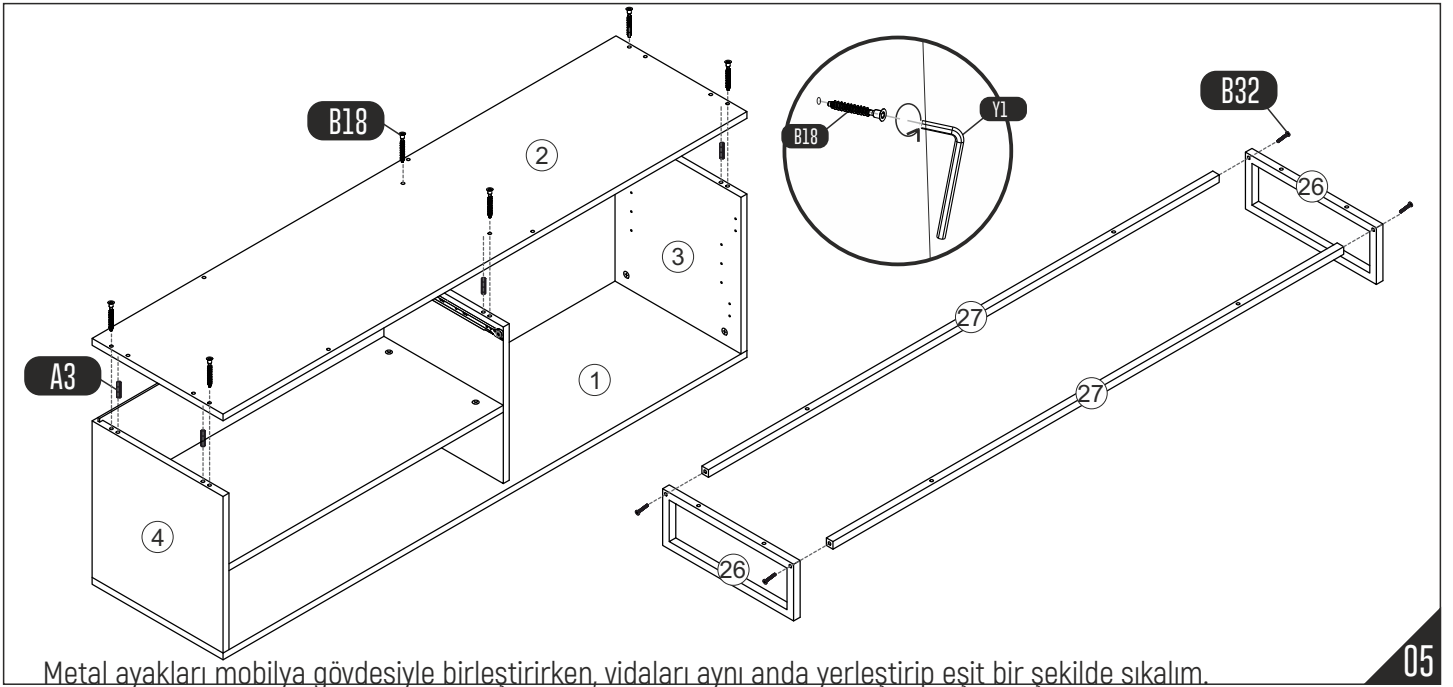
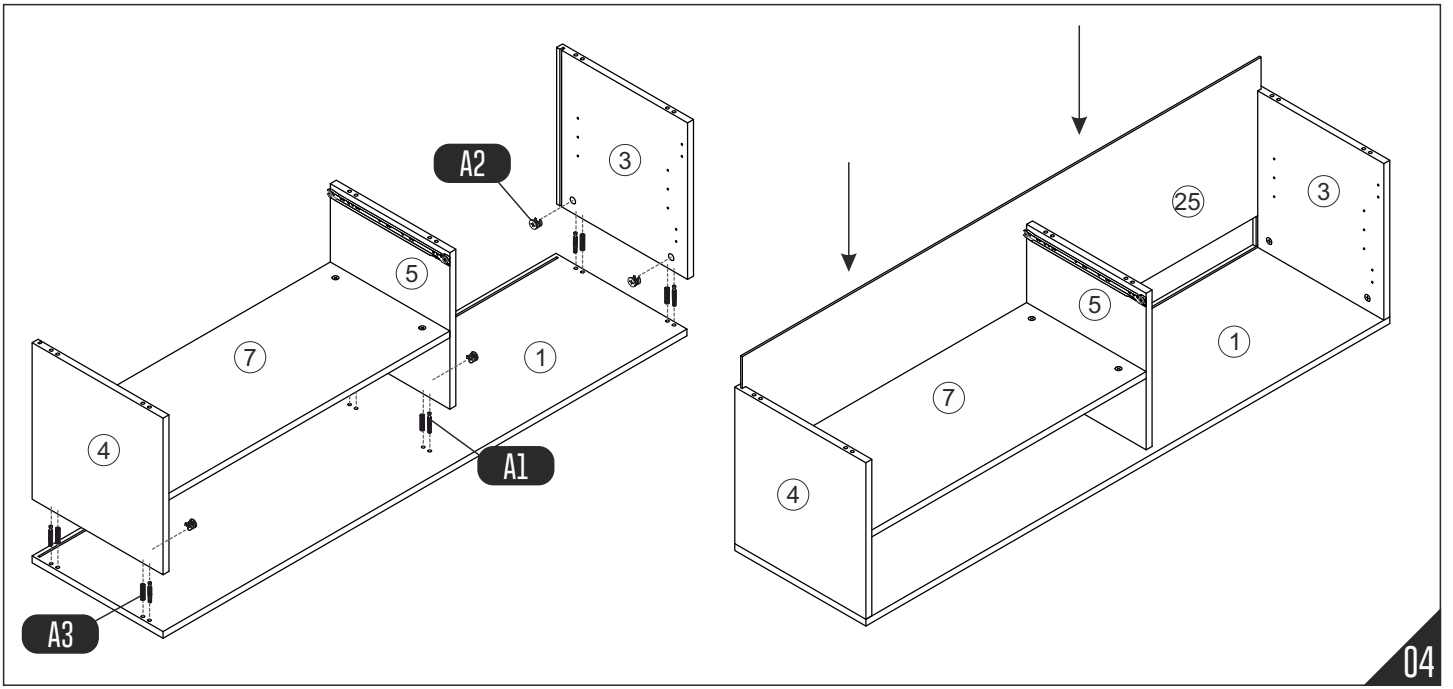

Metal ayakları mobilya gövdesiyle birleştirirken, vidaları aynı anda yerleştirip eşit bir şekilde sıkalım.

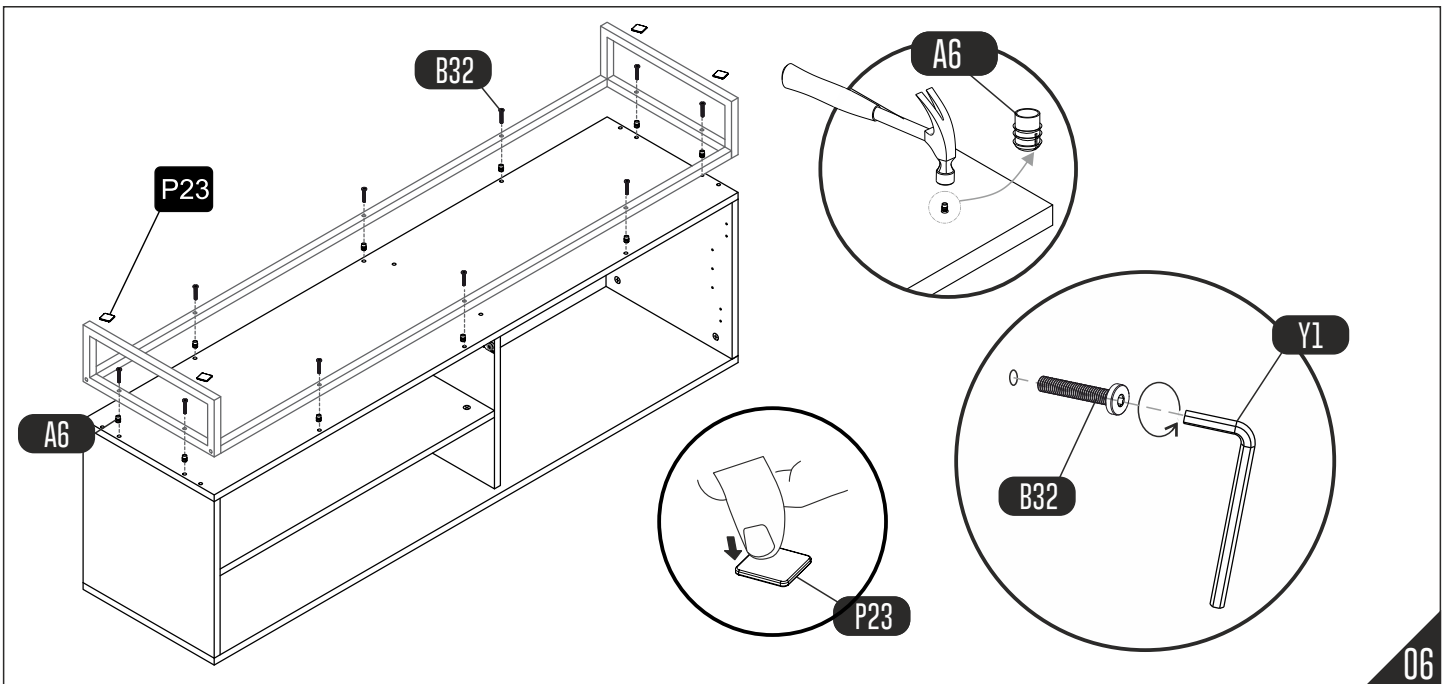

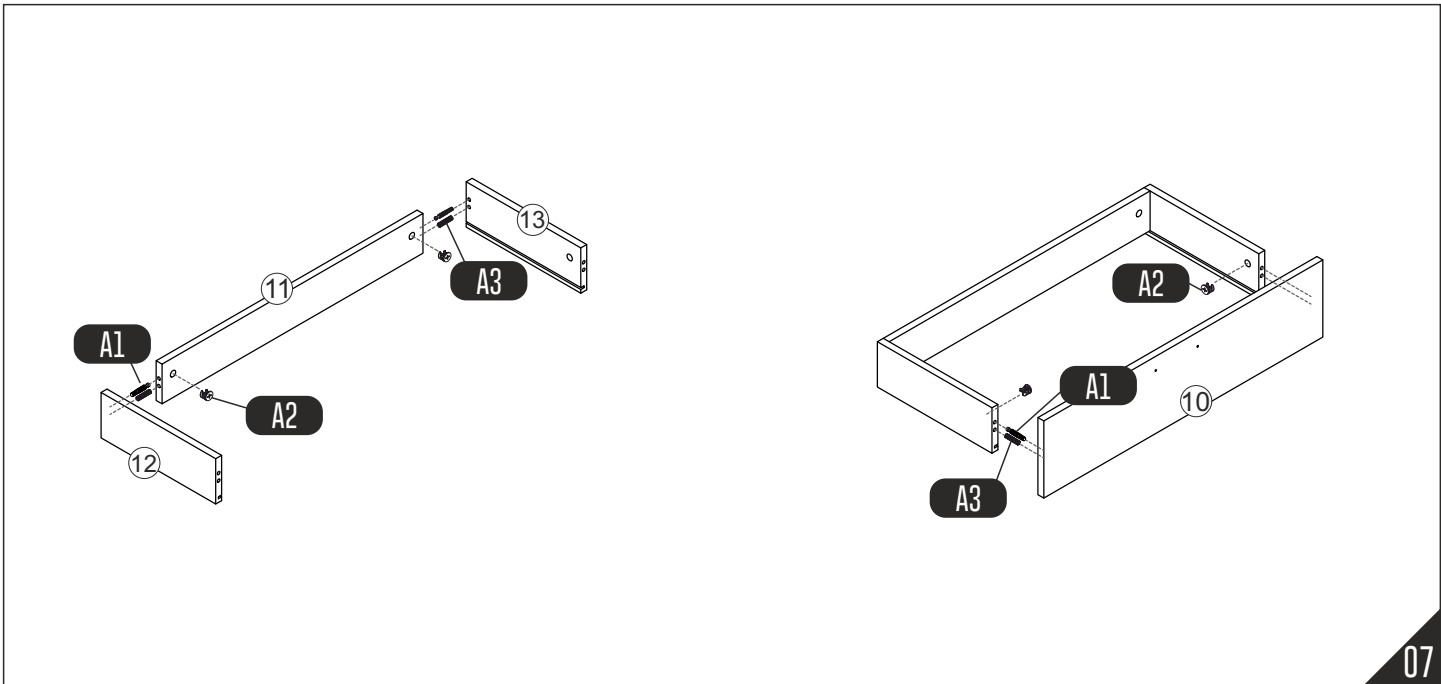

07

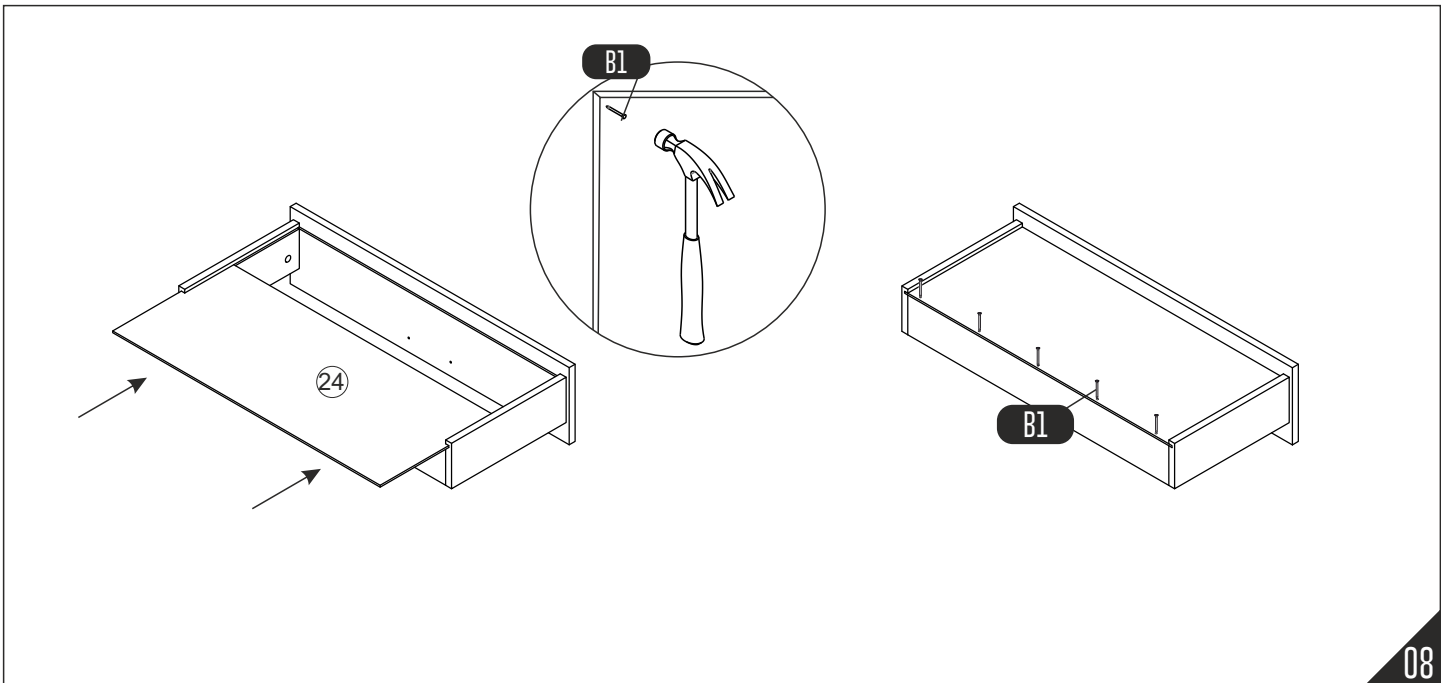

08

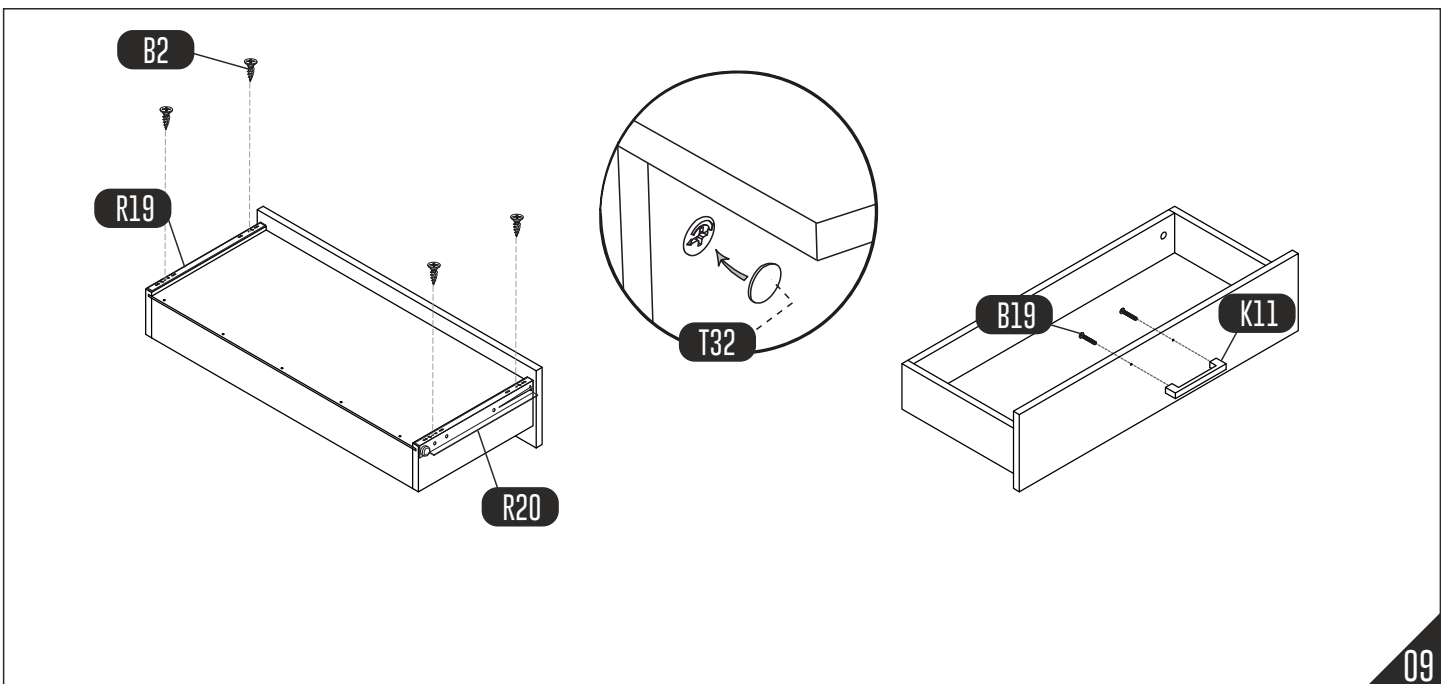

09

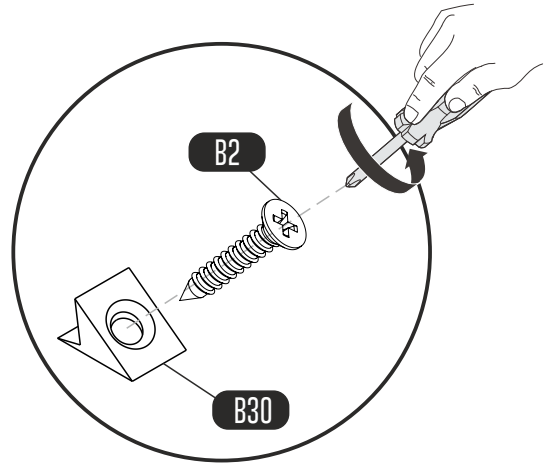
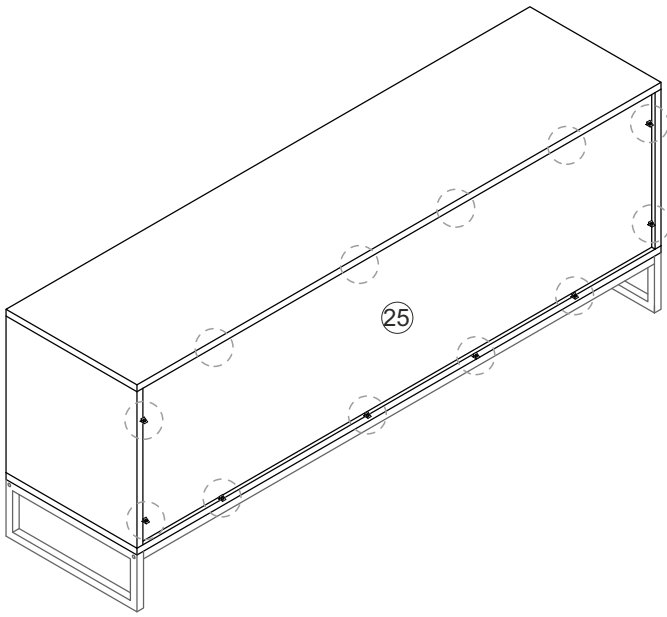

10

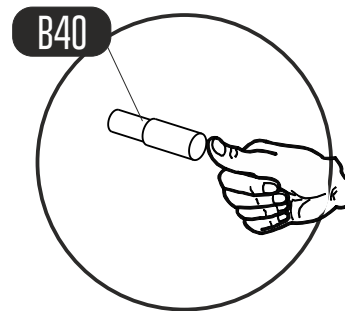
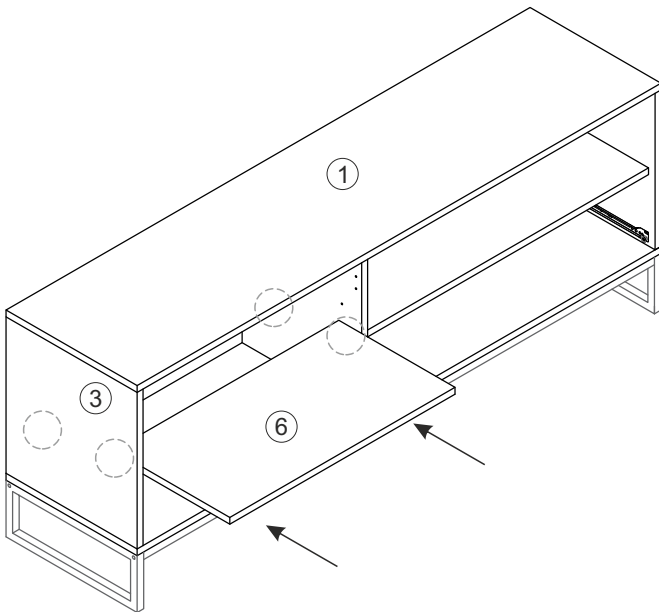

11

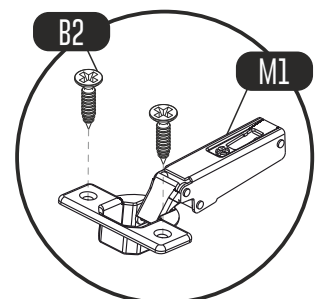
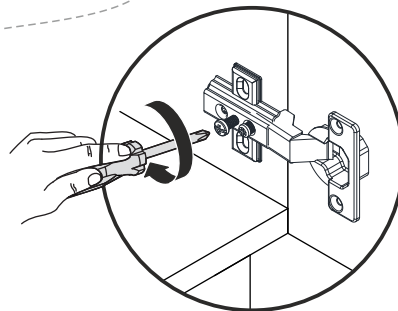
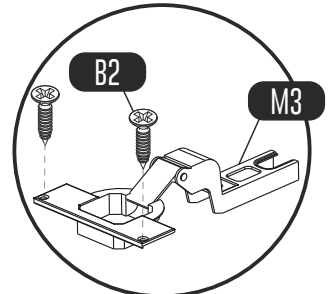
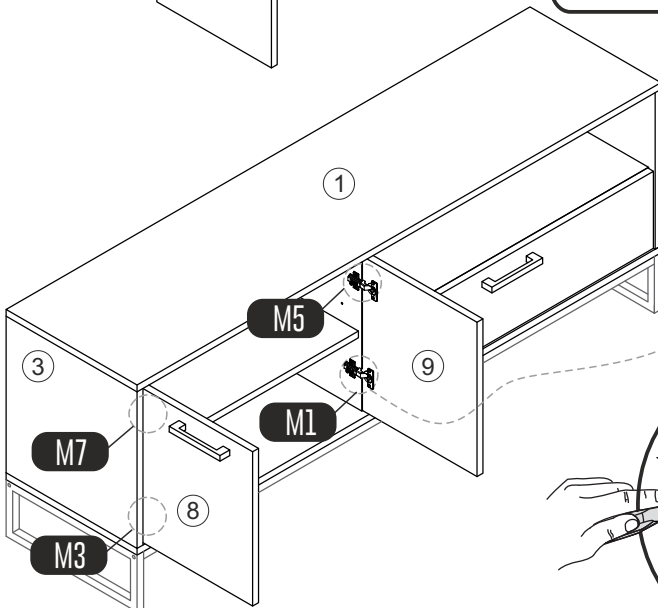
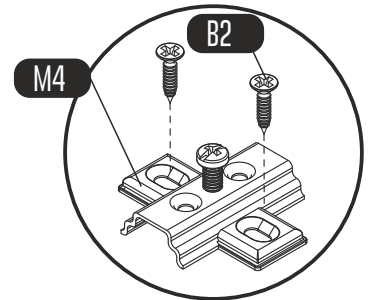
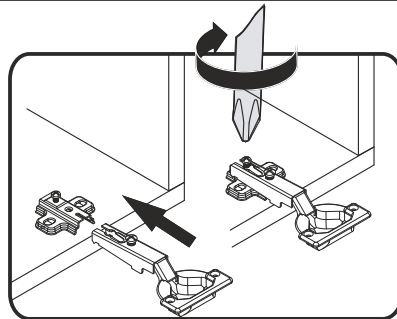
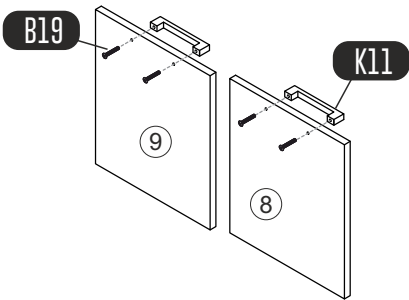
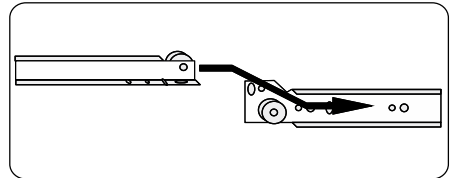
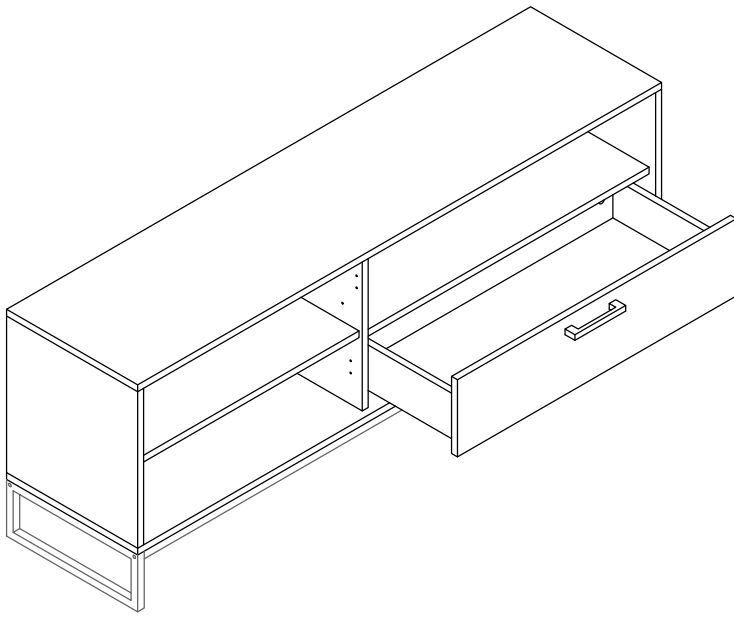

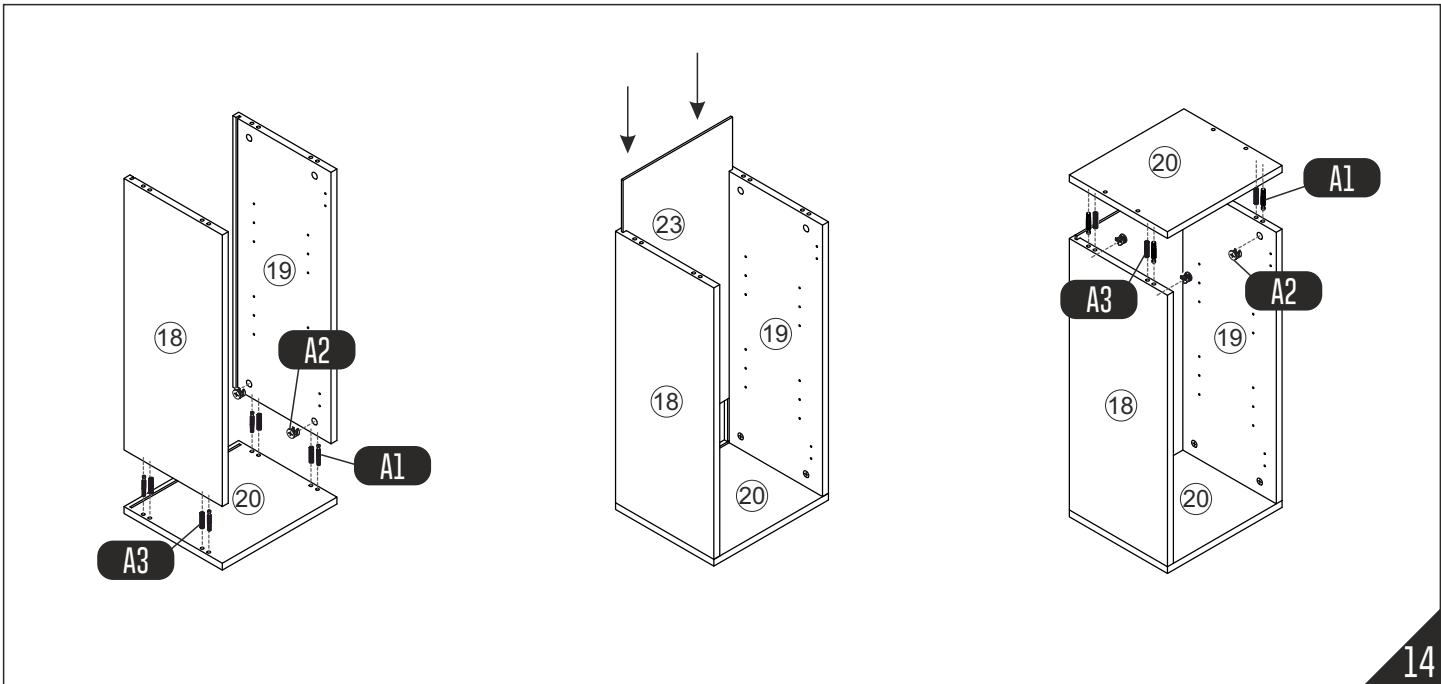

14

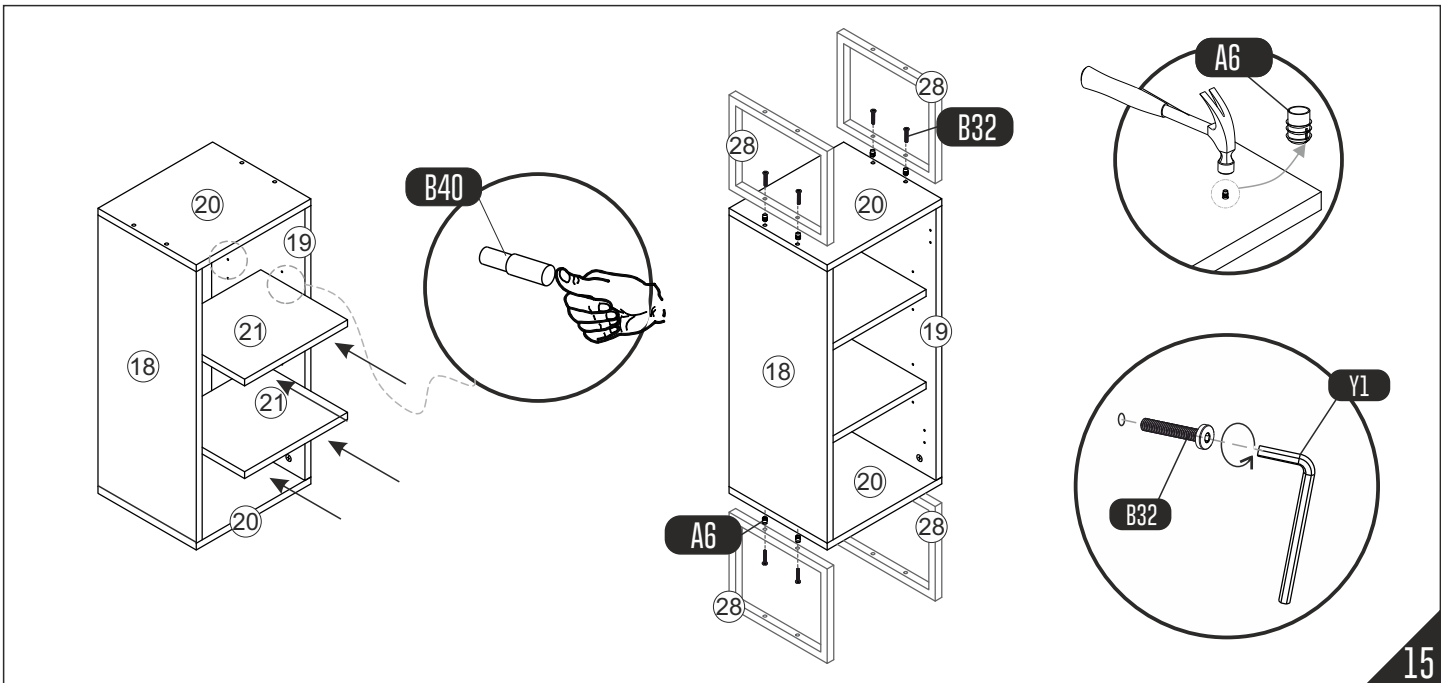

15

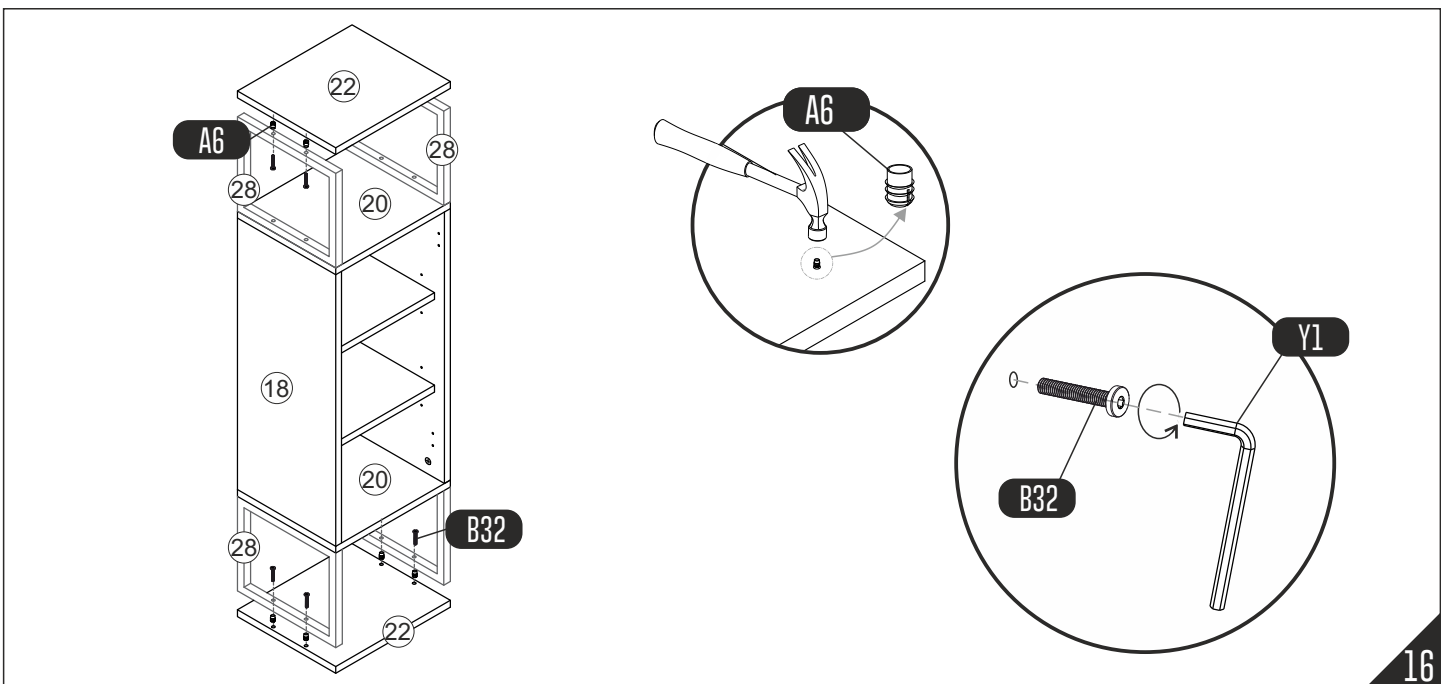

16

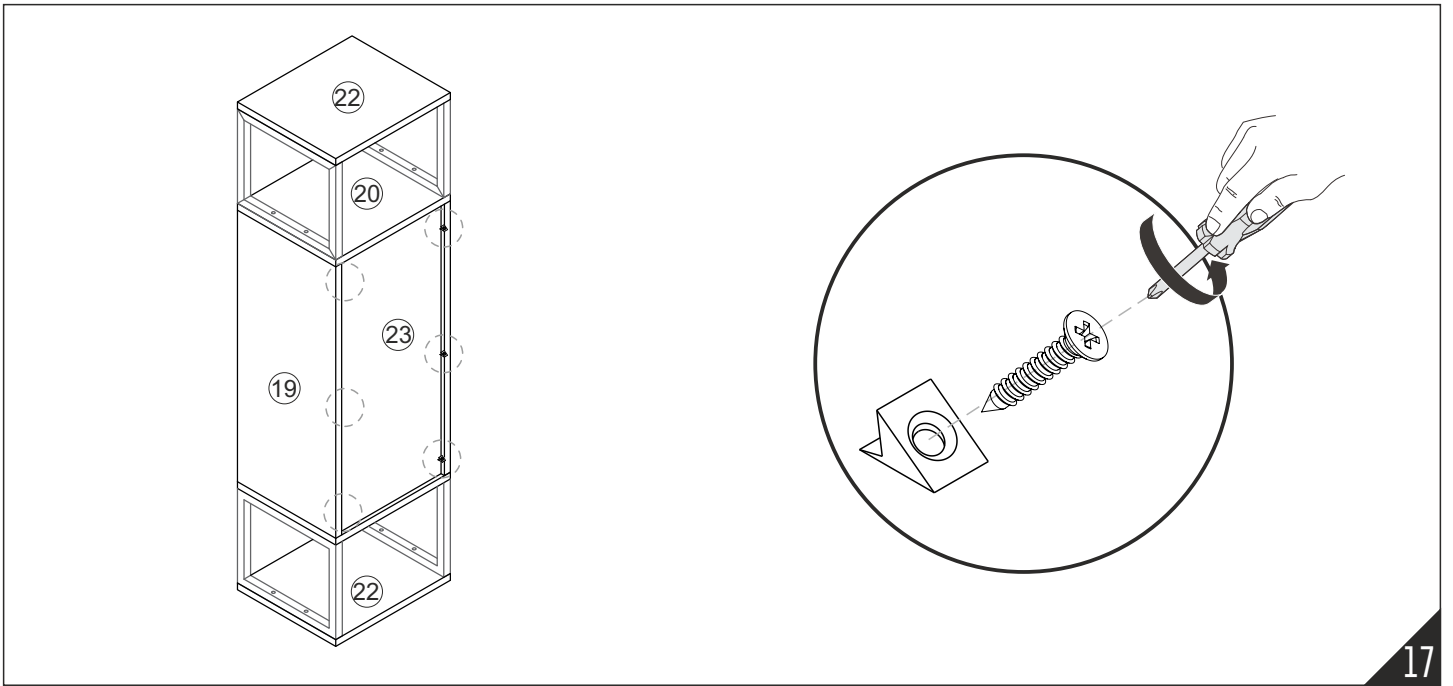

17

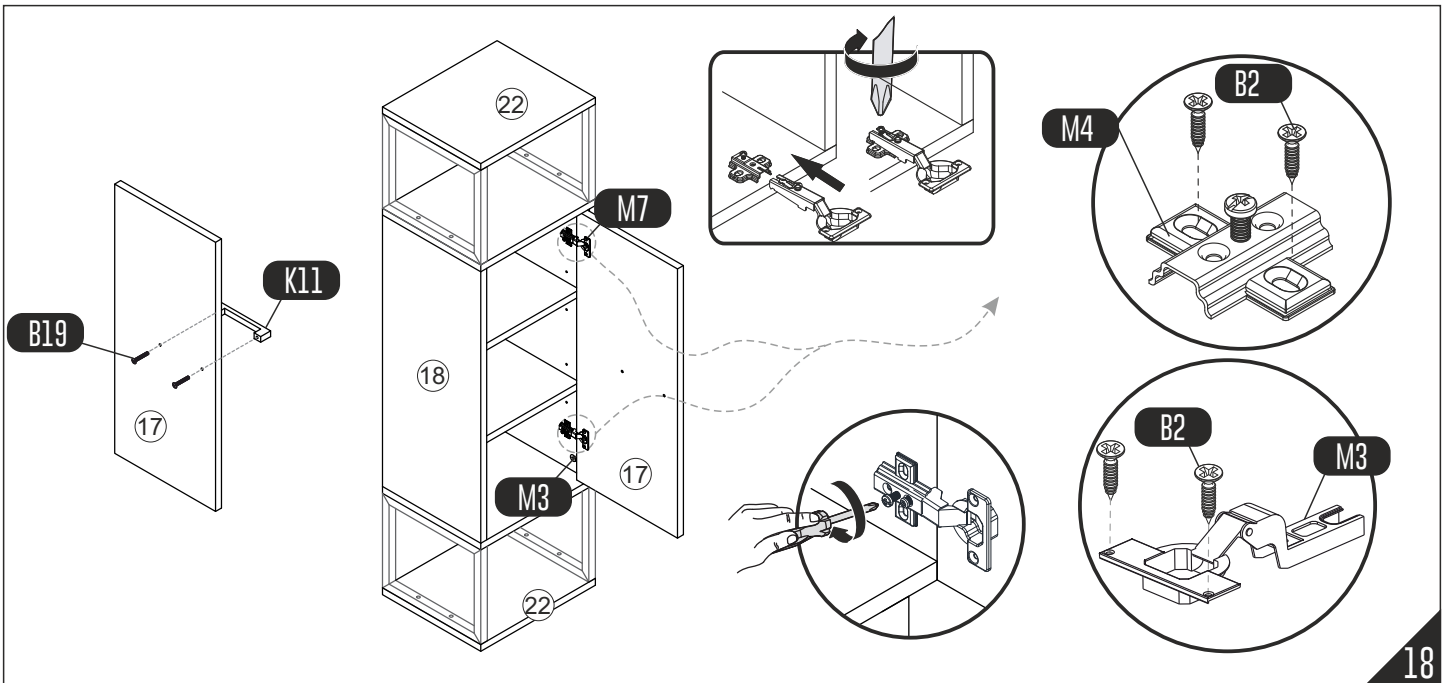

18

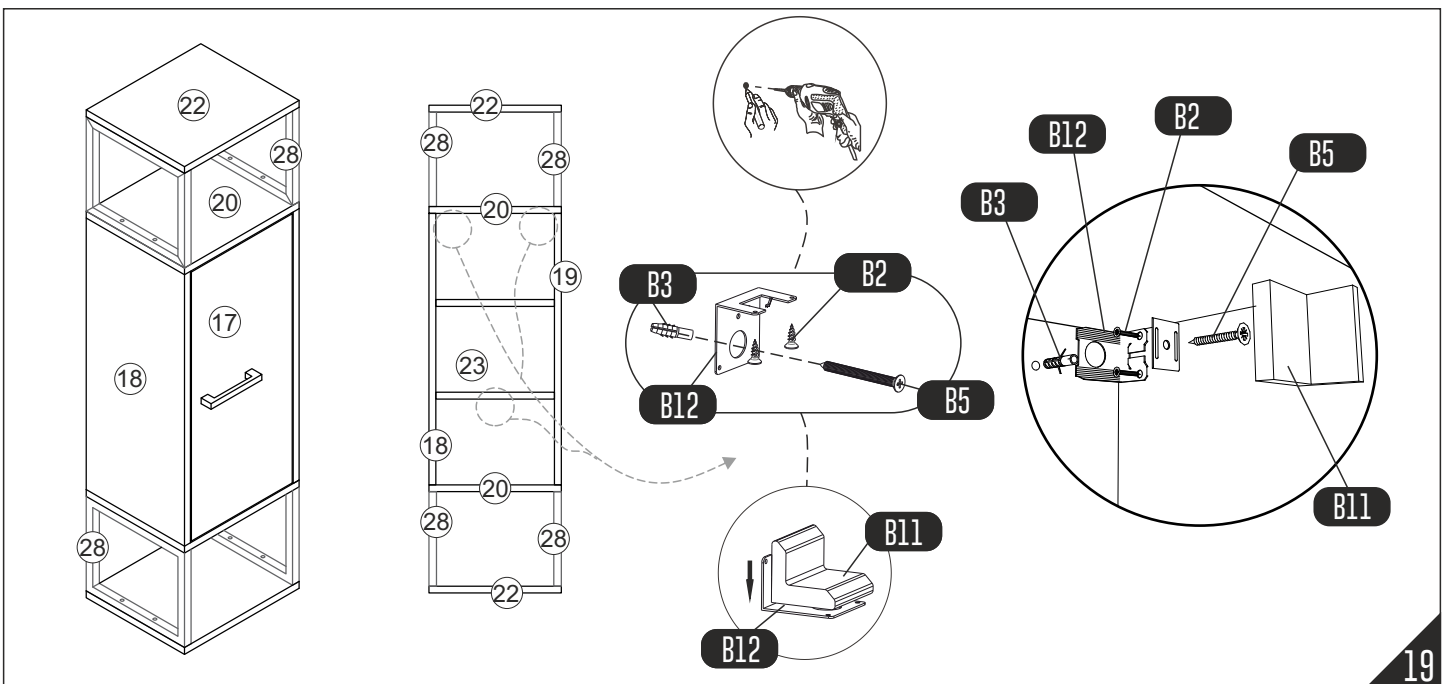

19

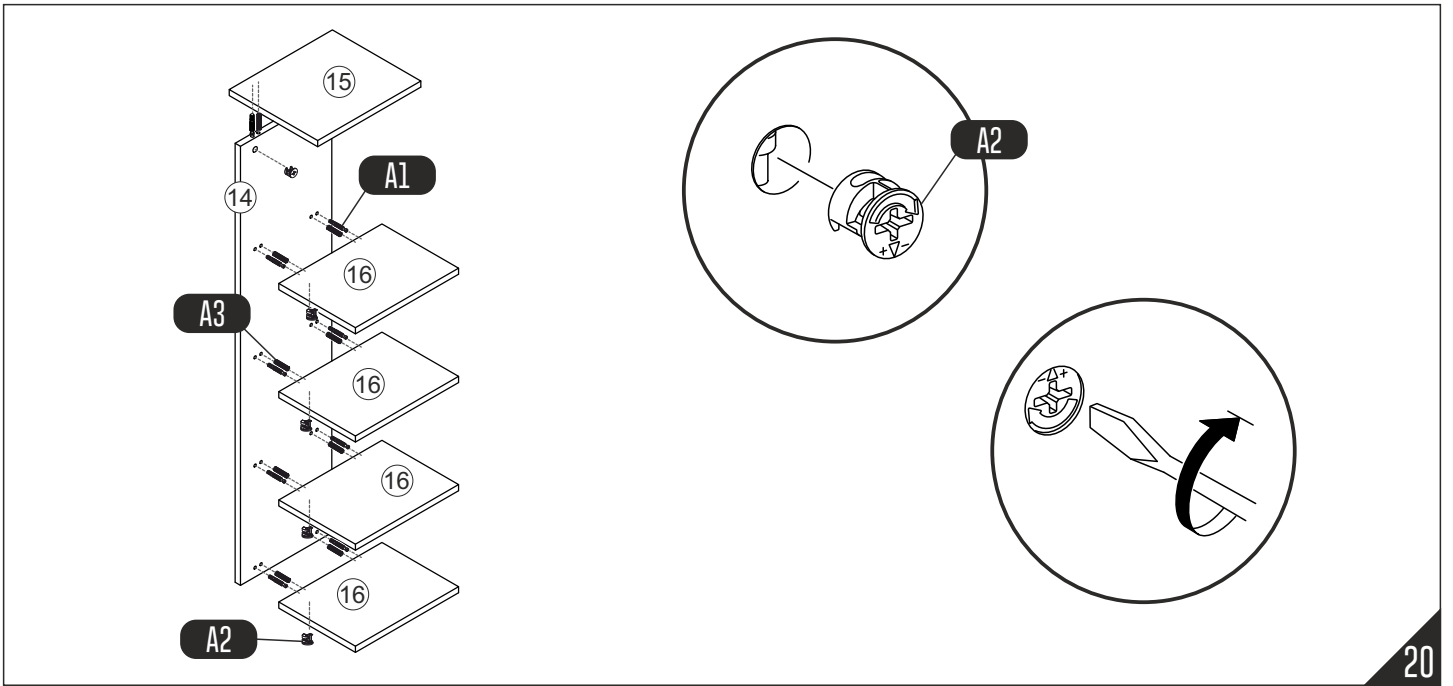

20

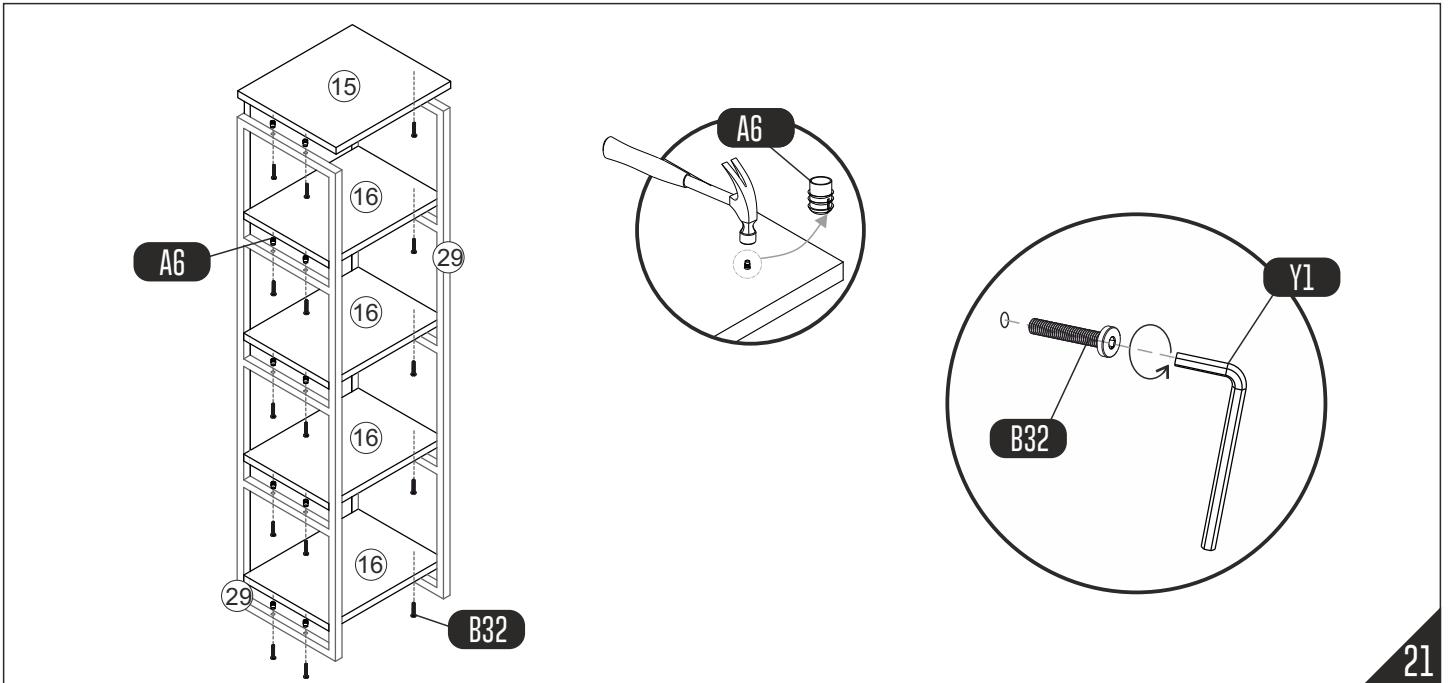

21

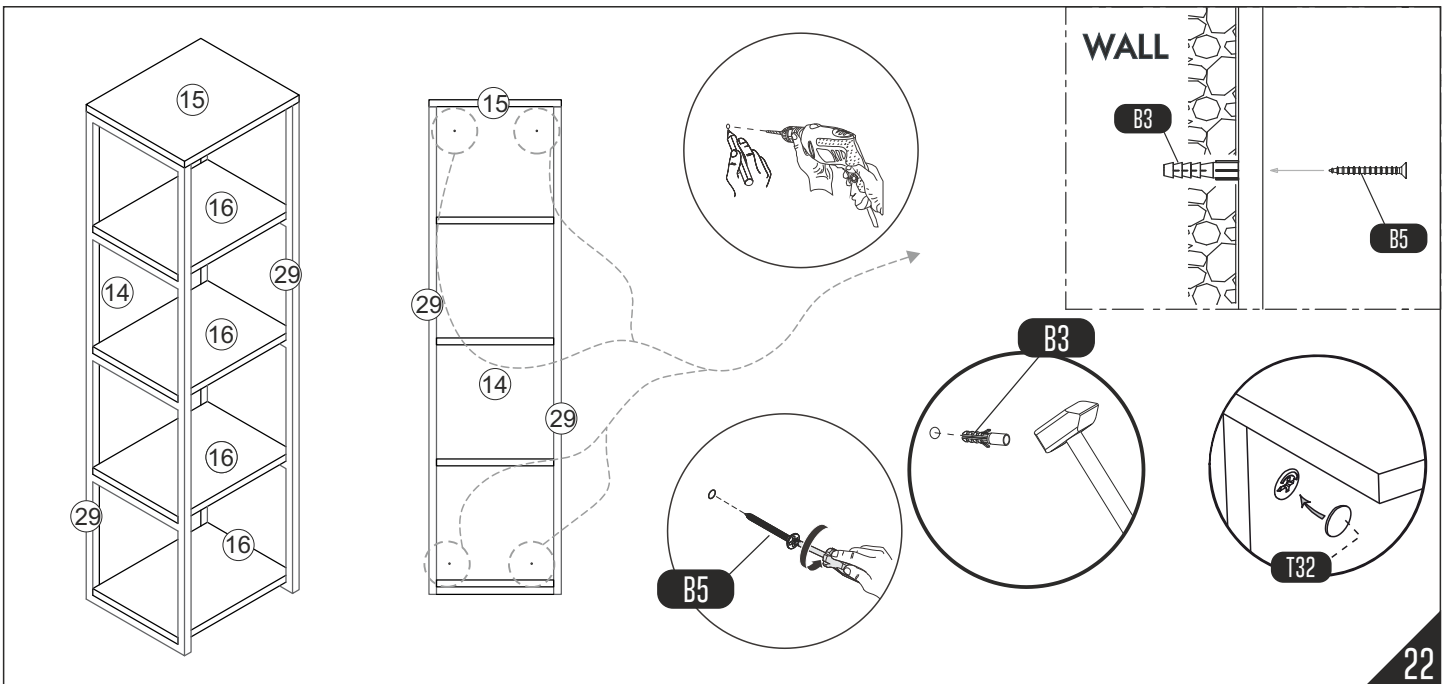

22

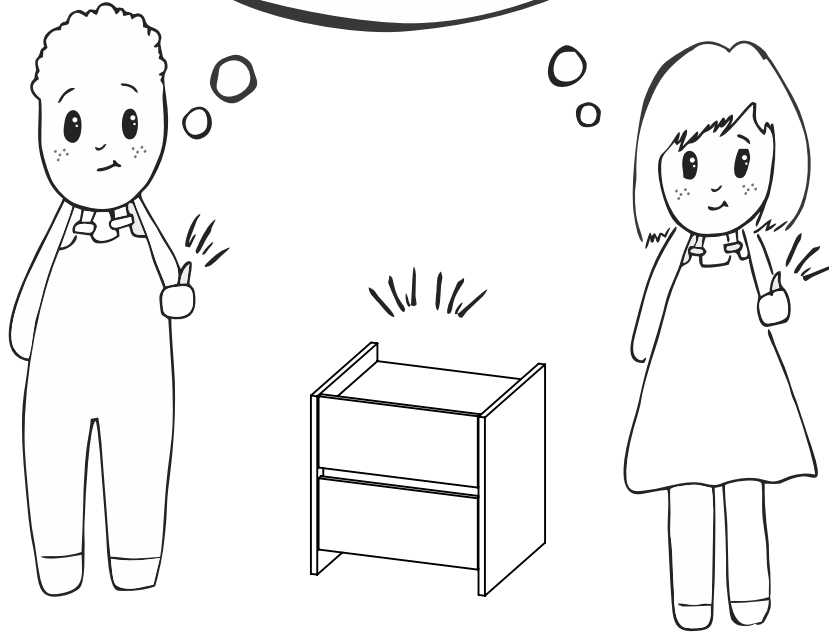

Have you seen our other products ?

www.furmet.com.tr

