

# yukon konsol

furmet

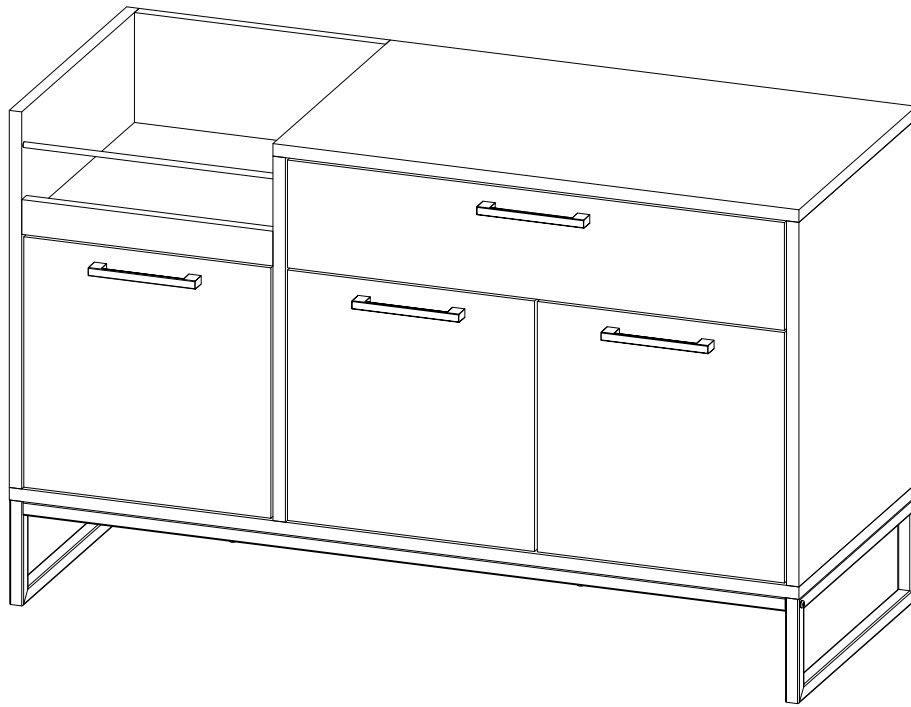

MOYEN-MEDIUM  
MITTEL-MEDIO

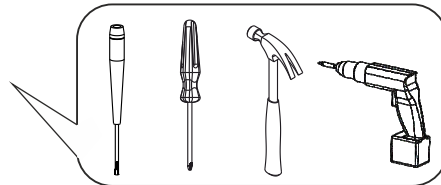
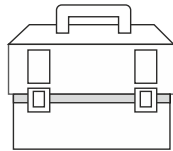
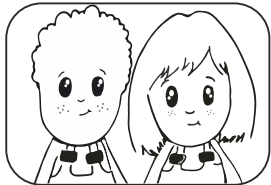

**TR/** Eğer ürününüzle ilgili yardıma ihtiyacınız olursa email: [info@furmet.com.tr](mailto:info@furmet.com.tr)

**UK/** If you need information about your product, email: [info@furmet.com.tr](mailto:info@furmet.com.tr)

**GE/** Wenn Sie Fragen zu Ihrem Produkt, email: [info@furmet.com.tr](mailto:info@furmet.com.tr)

**FR/** Si vous avez des questions sur votre produit, email: [info@furmet.com.tr](mailto:info@furmet.com.tr)

**ES/** Si tiene alguna pregunta acerca de su producto, email: [info@furmet.com.tr](mailto:info@furmet.com.tr)

**PT/** Se você tiver dúvidas sobre o seu produto, email: [info@furmet.com.tr](mailto:info@furmet.com.tr)

**SE/** Om du har frågor om din produkt, email: [info@furmet.com.tr](mailto:info@furmet.com.tr)

**NW/** Hvis du trenger informasjon om produktet, email: [info@furmet.com.tr](mailto:info@furmet.com.tr)

**IT/** Se hai delle domande sul tuo articolo, ecco la mail via nuestro website

**PL/** Jeśli mają Państwo pytania dotyczące produktu, email: [info@furmet.com.tr](mailto:info@furmet.com.tr)

**RU/** Если Вам необходима дополнительная информация о товаре, свяжитесь с нами по email: [info@furmet.com.tr](mailto:info@furmet.com.tr)

hey you!

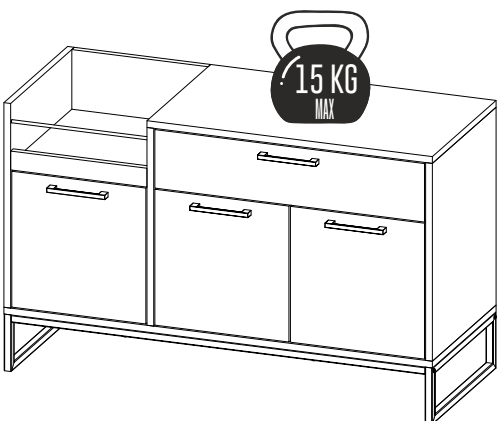
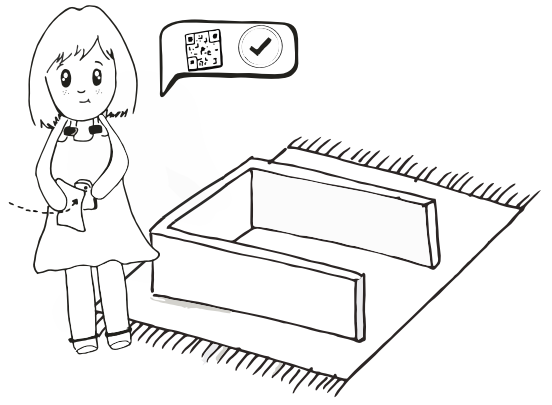
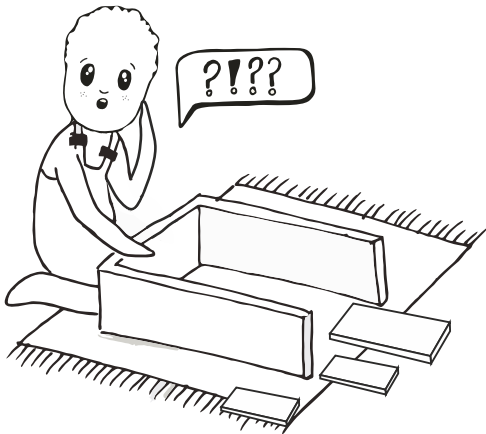
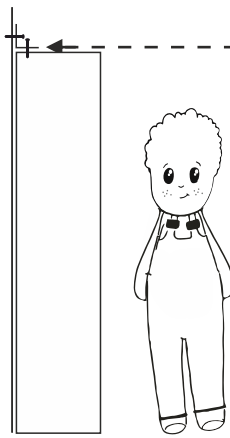
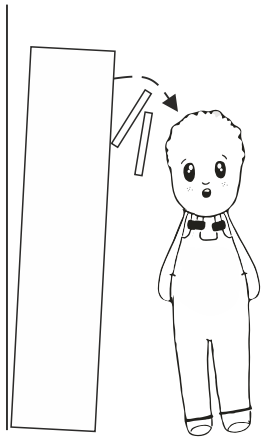
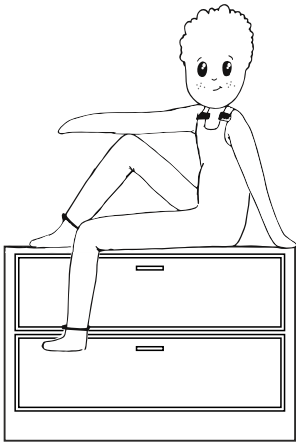

PS: Clean only with a damp cloth.  
NOT: Yalnızca nemli bir bezle temizleyiniz.

# caution!

Minifix is the main connection material used in products. Before starting assembly, please check the drawings below.

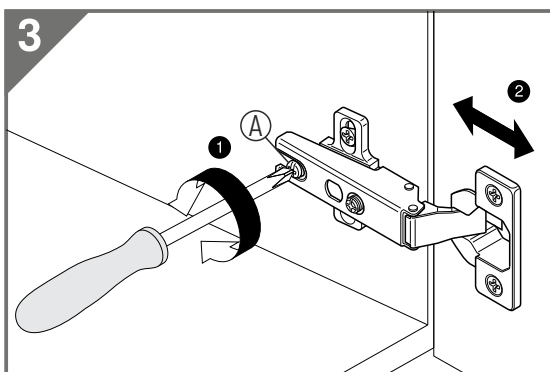
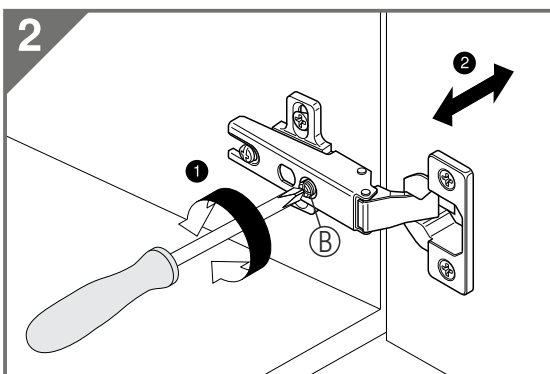
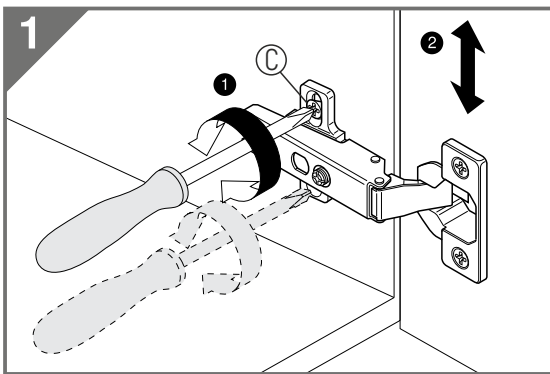
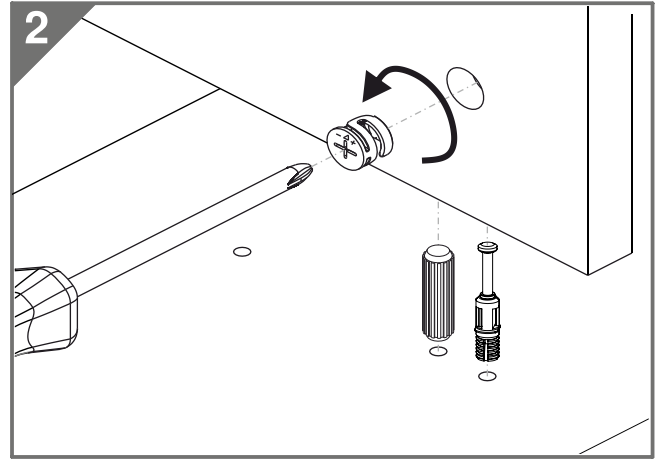
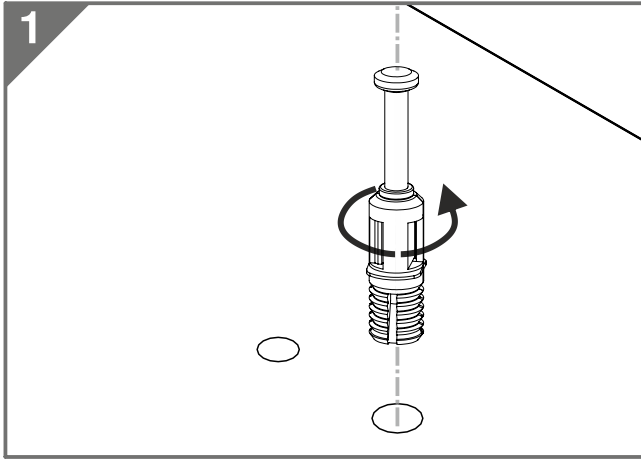

Height adjustment: Loosen screw 'C', adjust height, retighten screw 'C'.

Depth adjustment: Loosen fixing 'A', push hinge arm forwards or backwards, retighten screw 'A', fix screw 'B' with a 1/4- turn in clock-wise direction.

Side adjustment: Loosen fixing screw 'A', adjust gap with screw 'B' and retighten screw 'A'.

# TOOLBOX

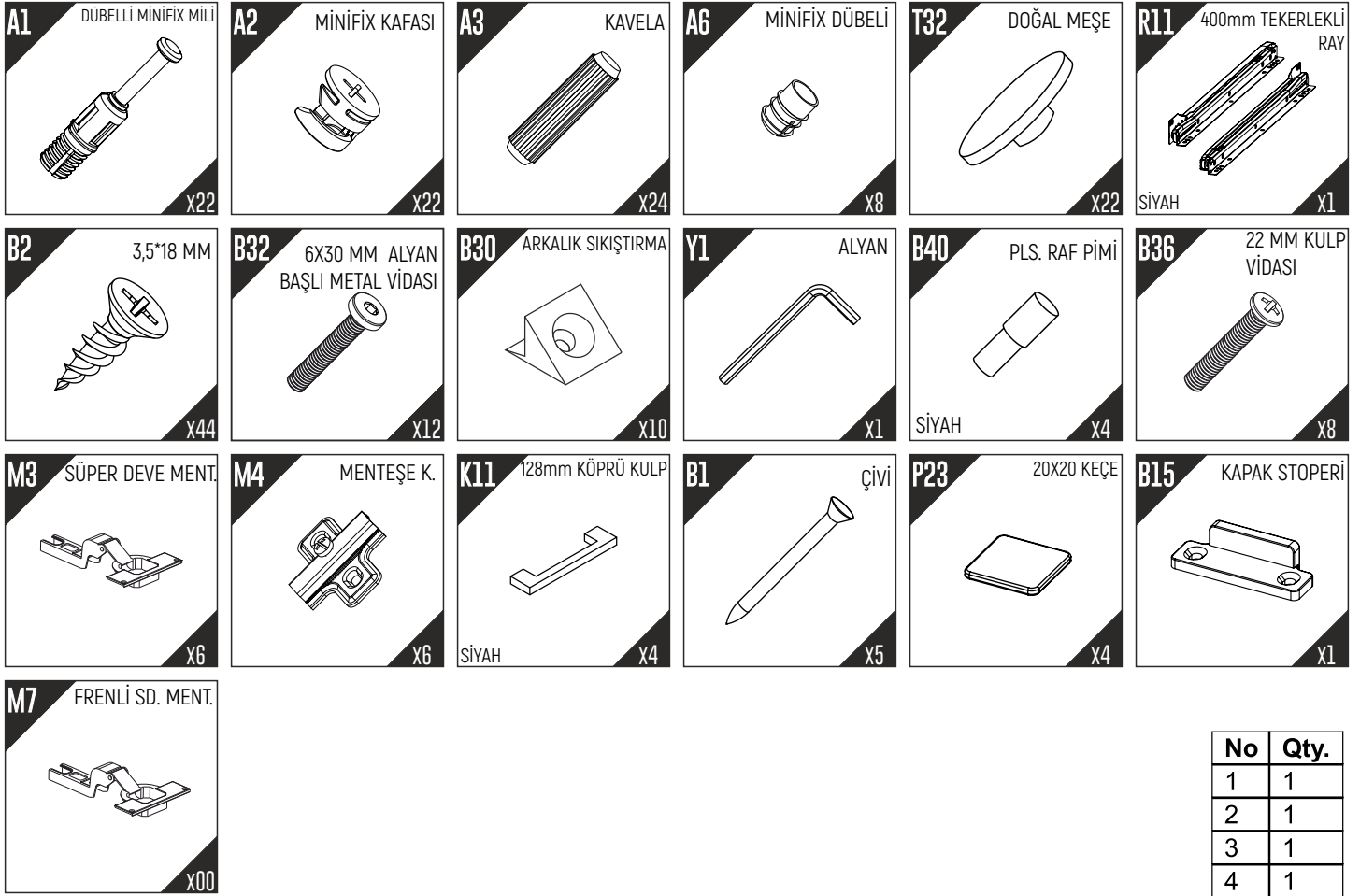

No	Qty.
1	1
2	1
3	1
4	1
5	1
6	1
7	1
8	1
9	1
10	2
11	1
12	1
13	1
14	1
15	1
16	1
17	1
18	2
19	2
20	2
21	1

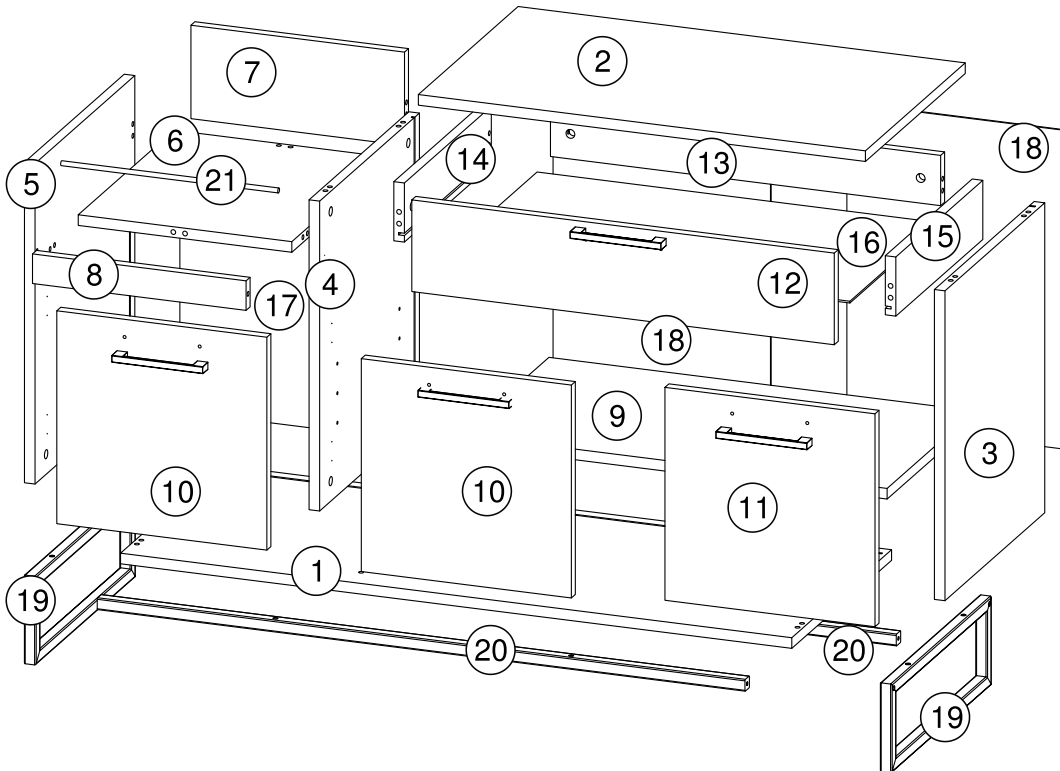

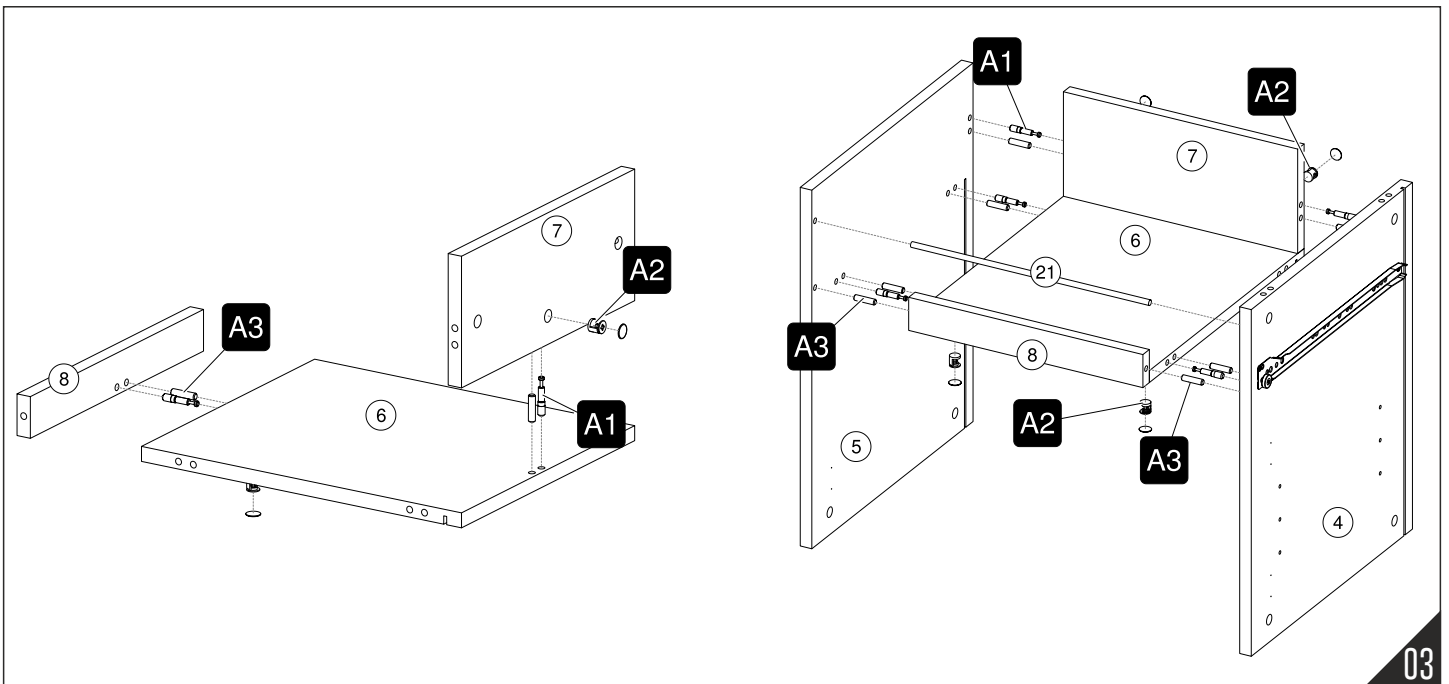
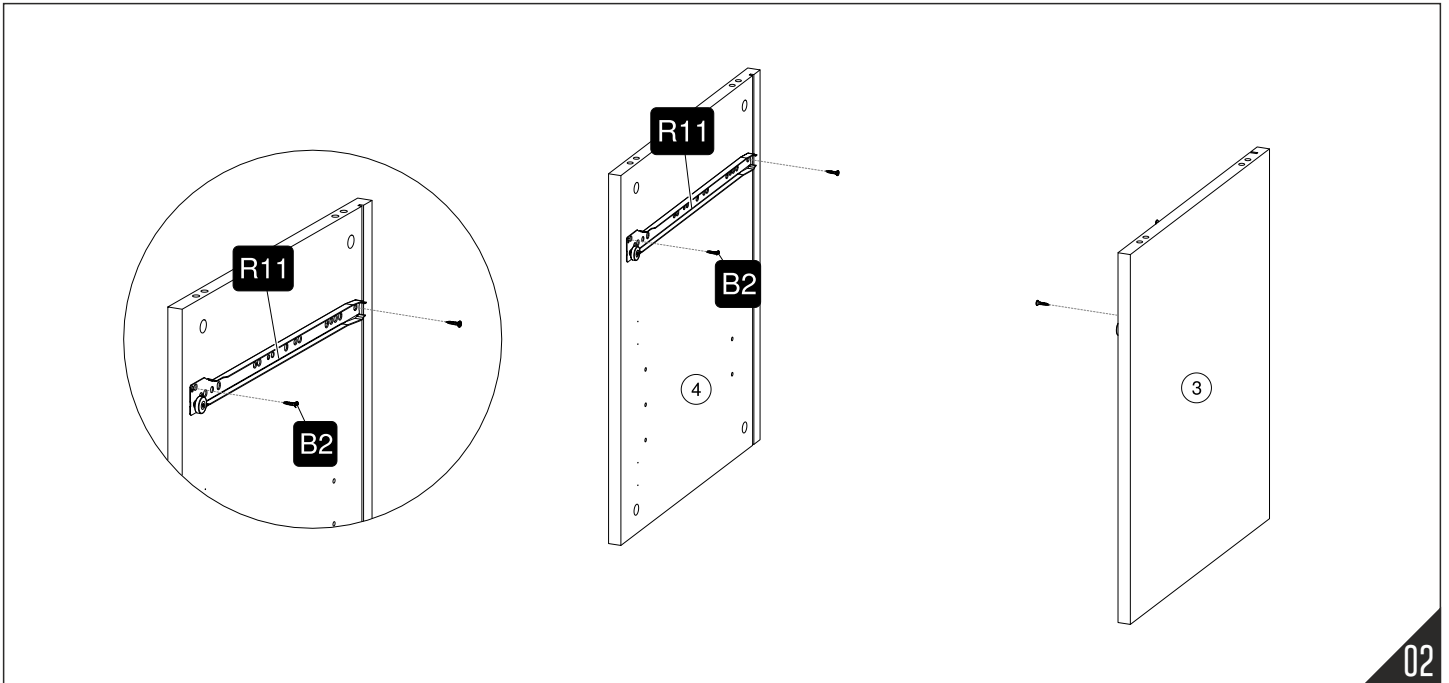
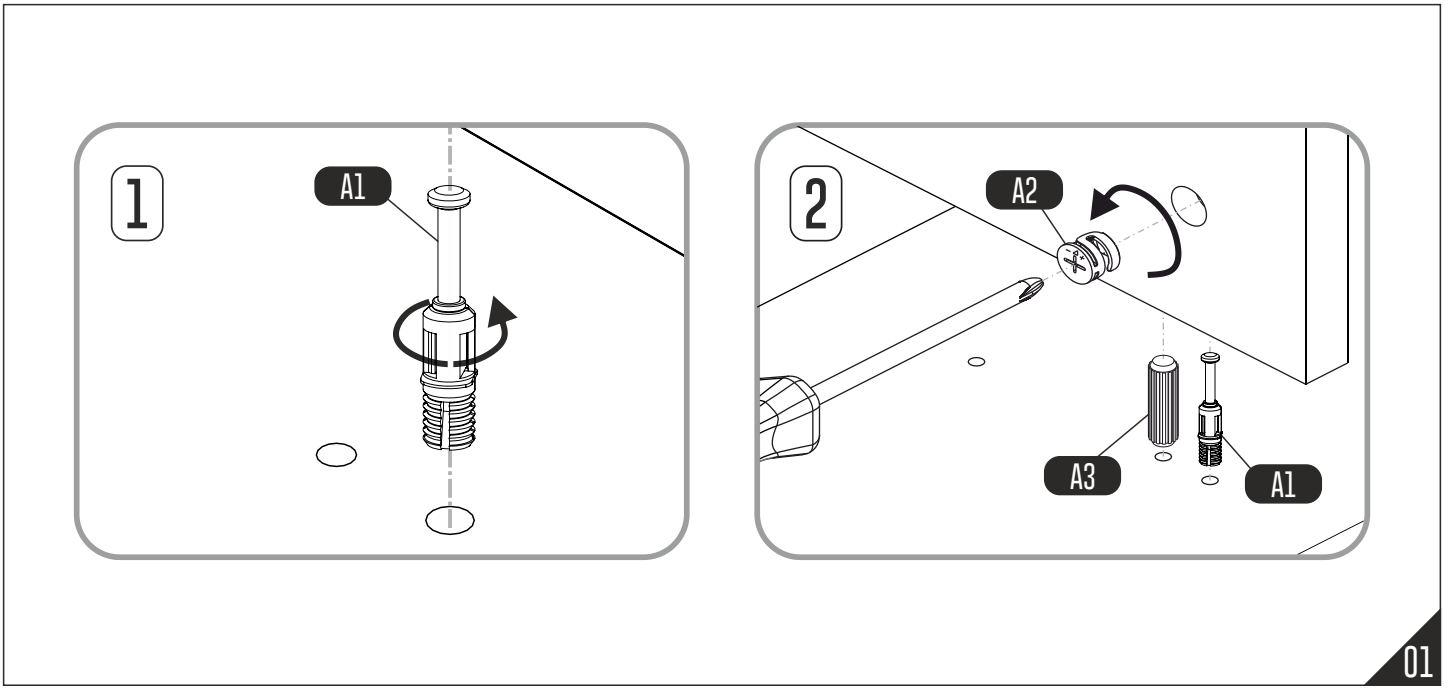

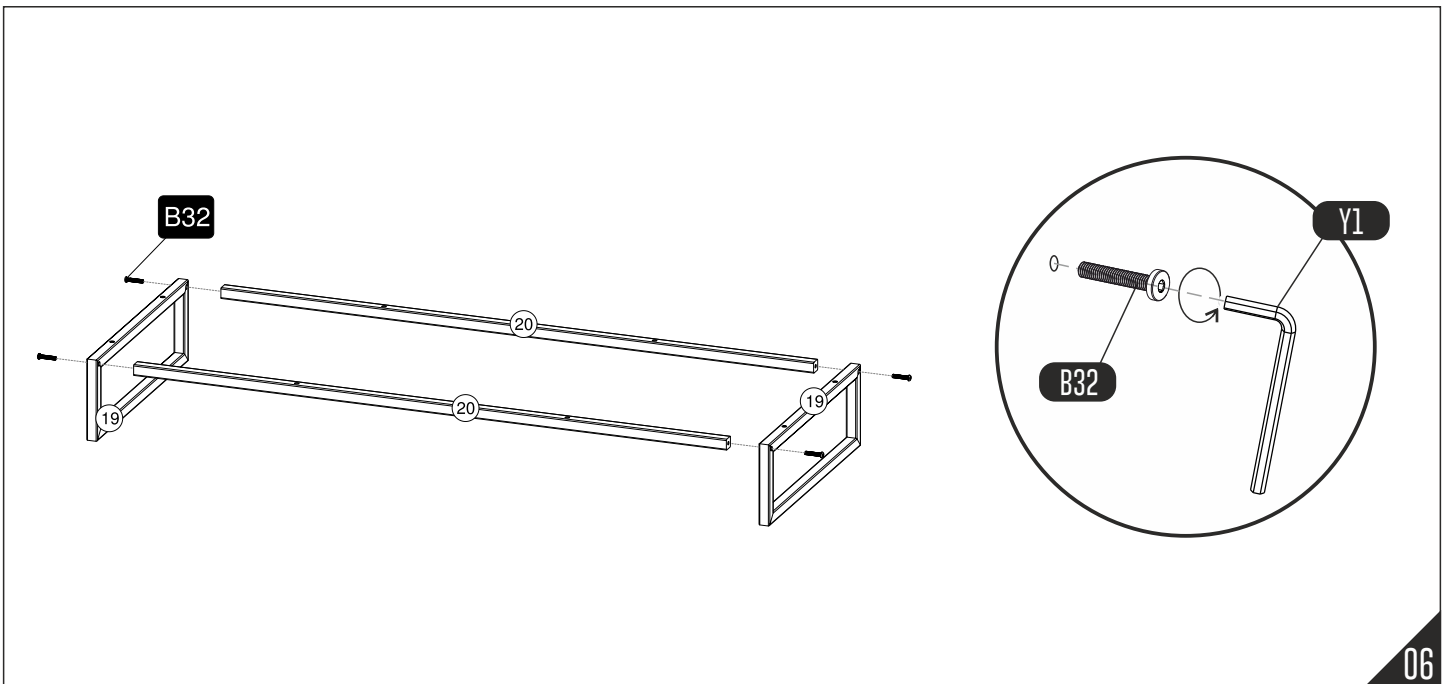
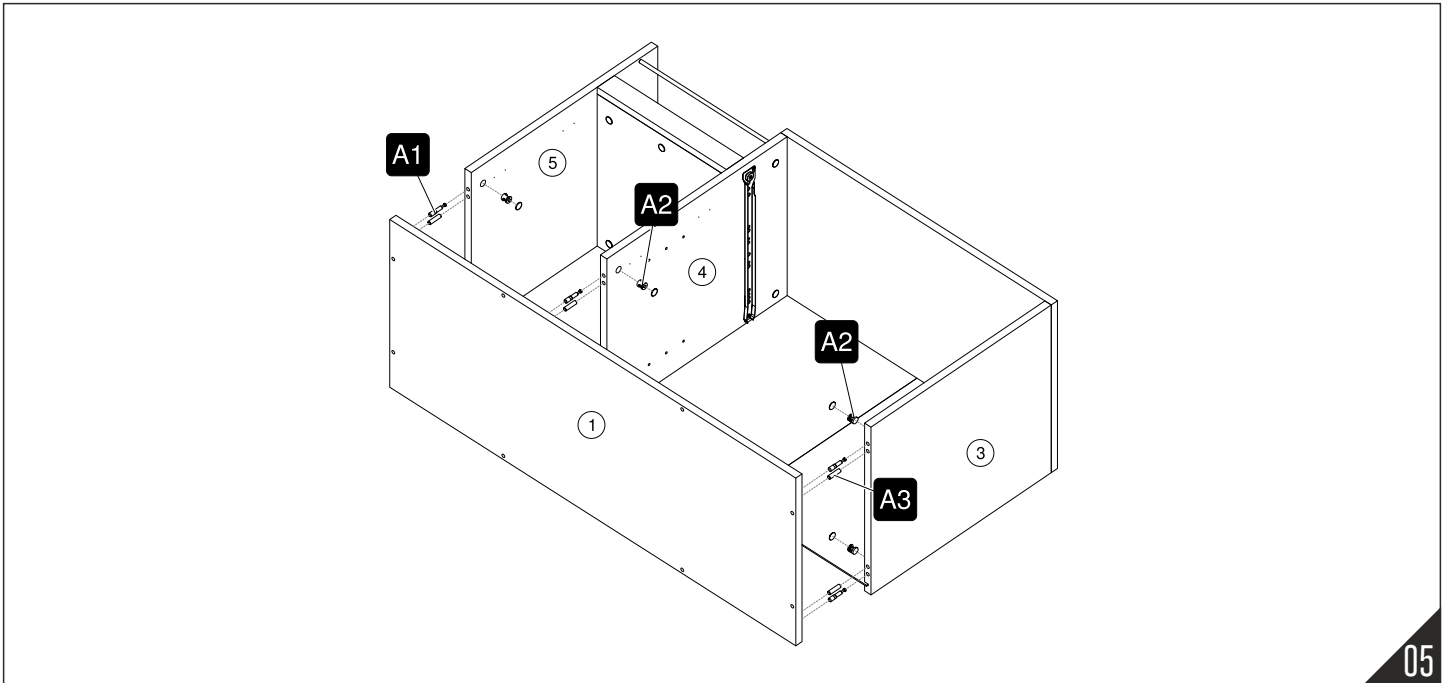
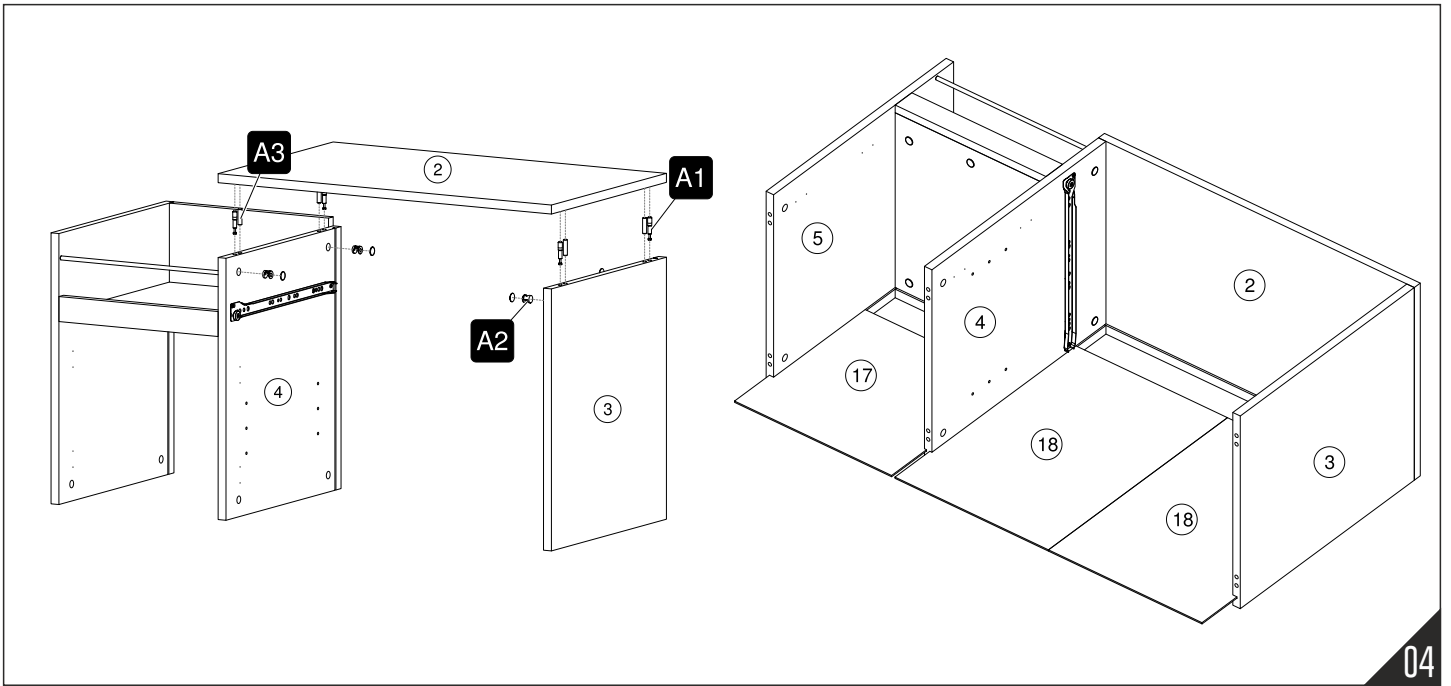

Metal ayakları mobilya gövdesiyle birleřtirirken, vidaları aynı anda yerleřtirip eřit bir řekilde sıkalım.

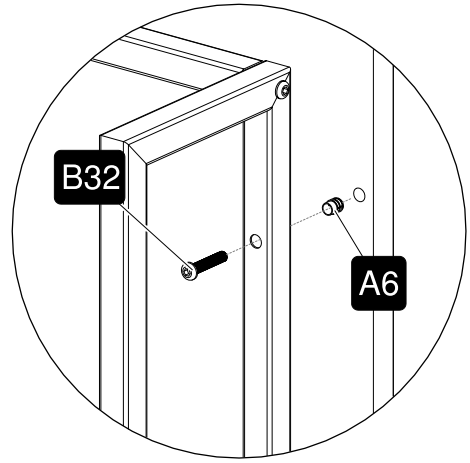
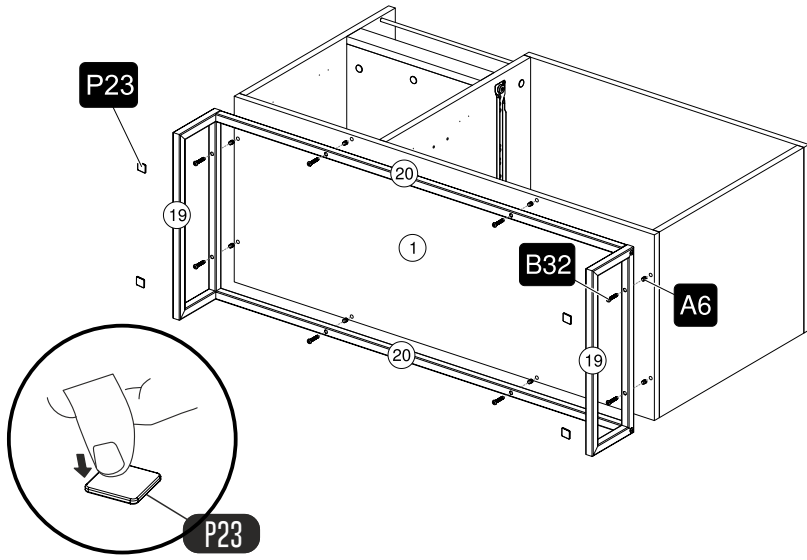

07

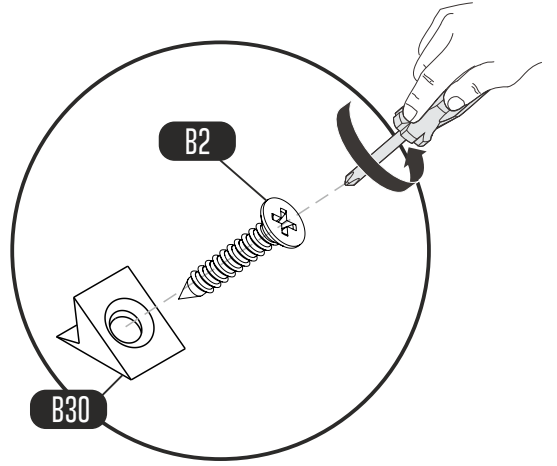
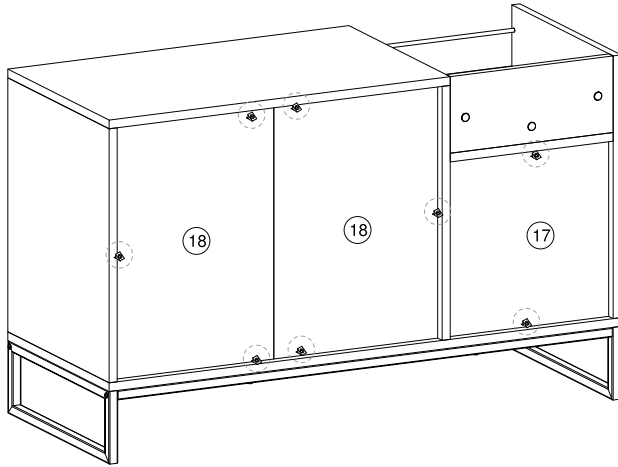

08

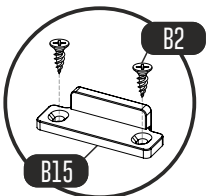
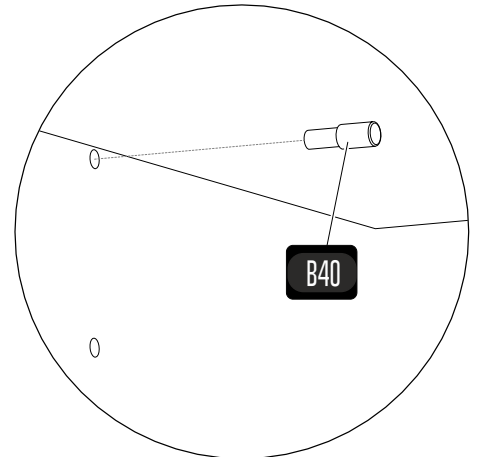
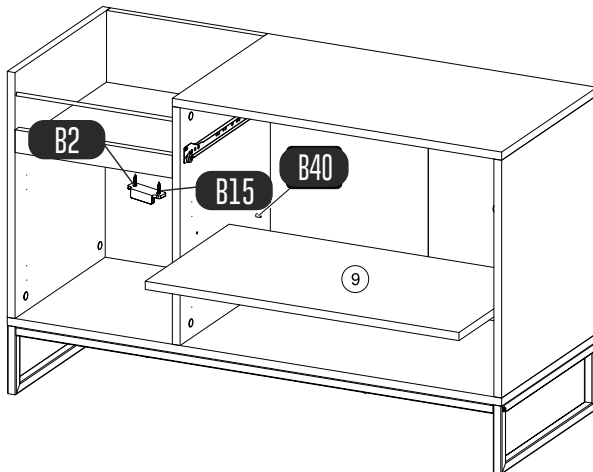

09

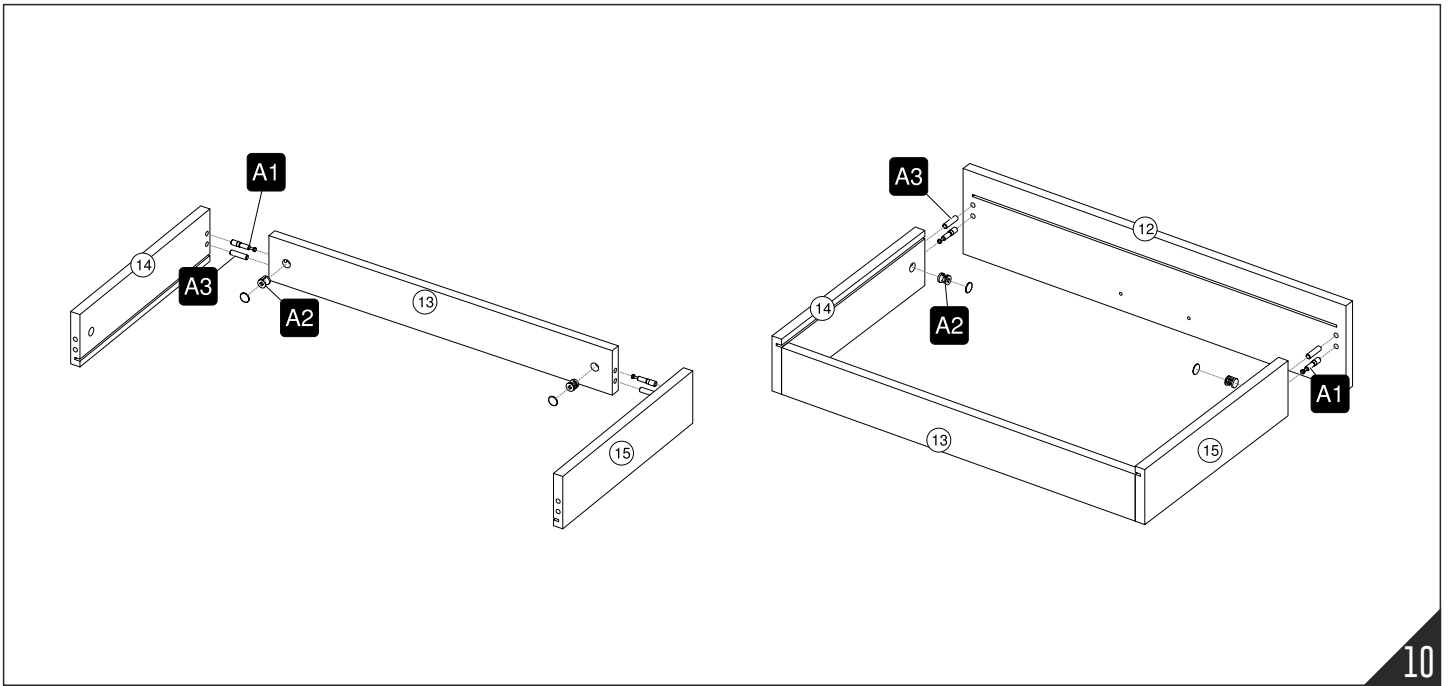

10

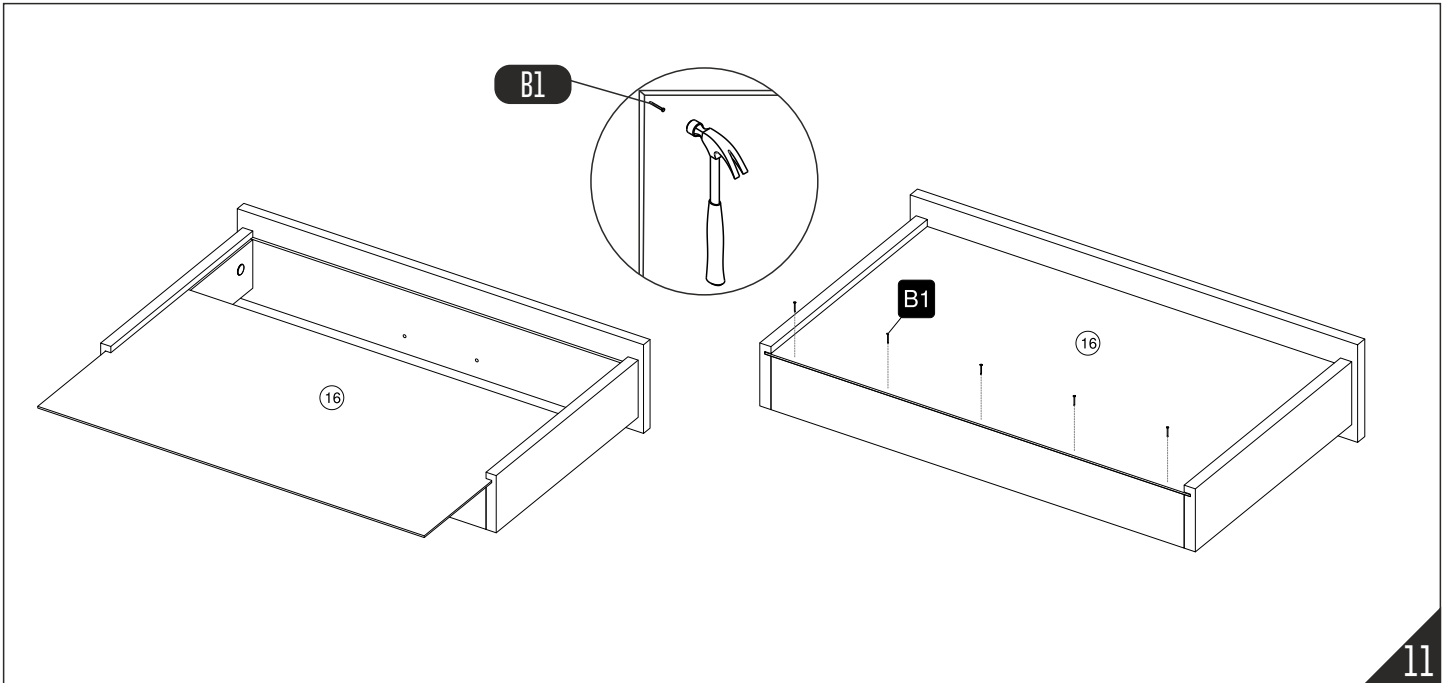

11

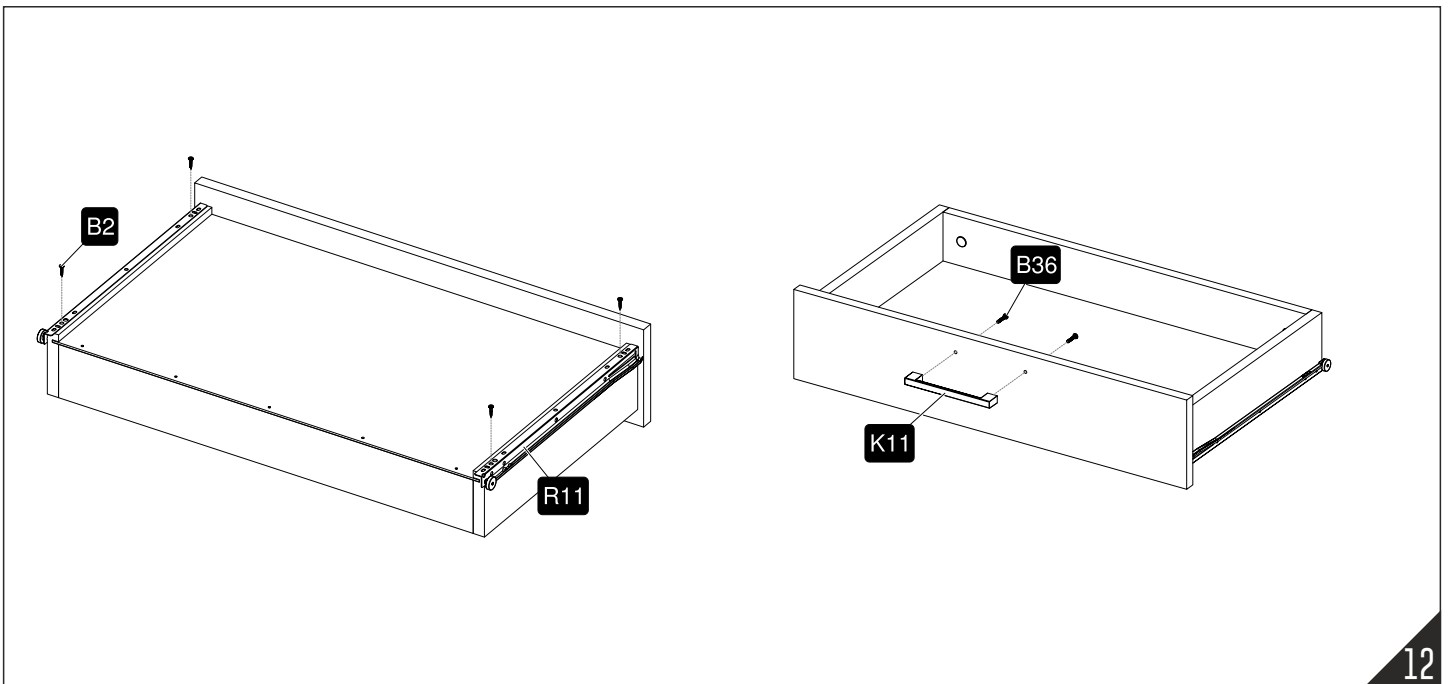

12



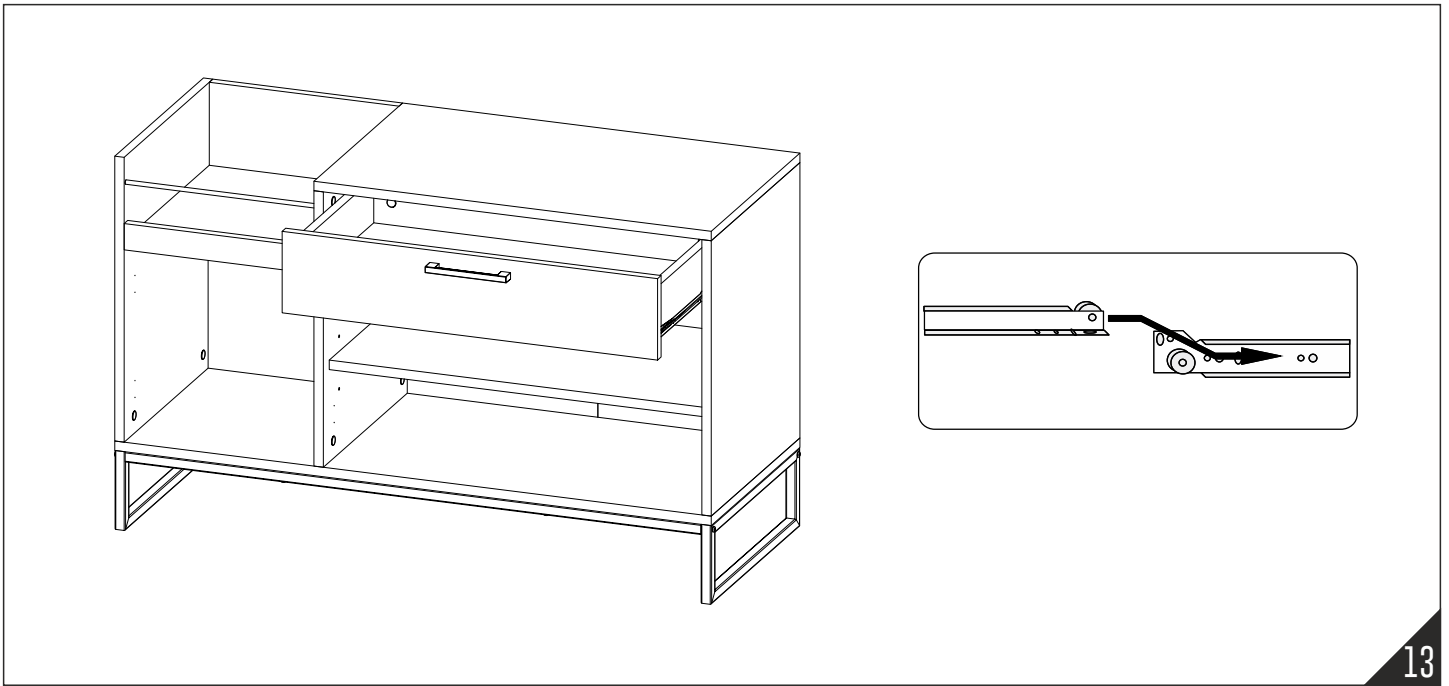

13

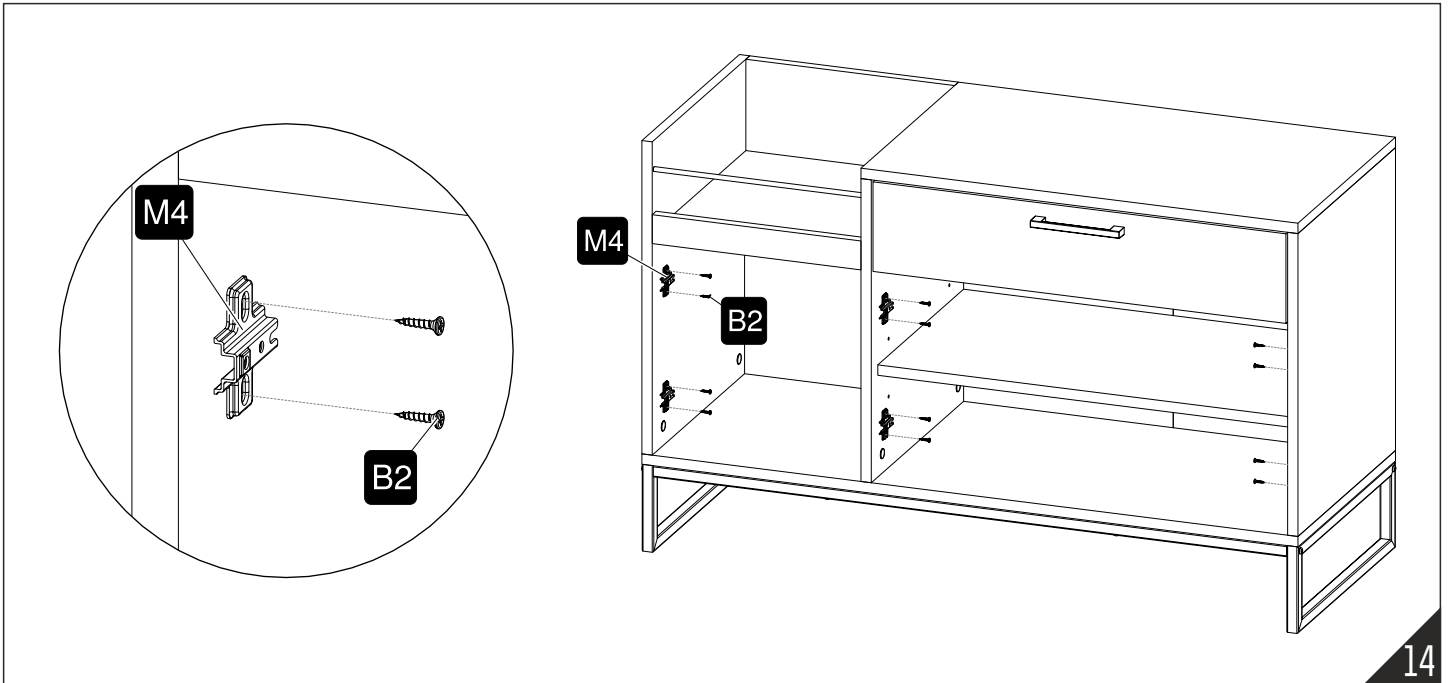

14

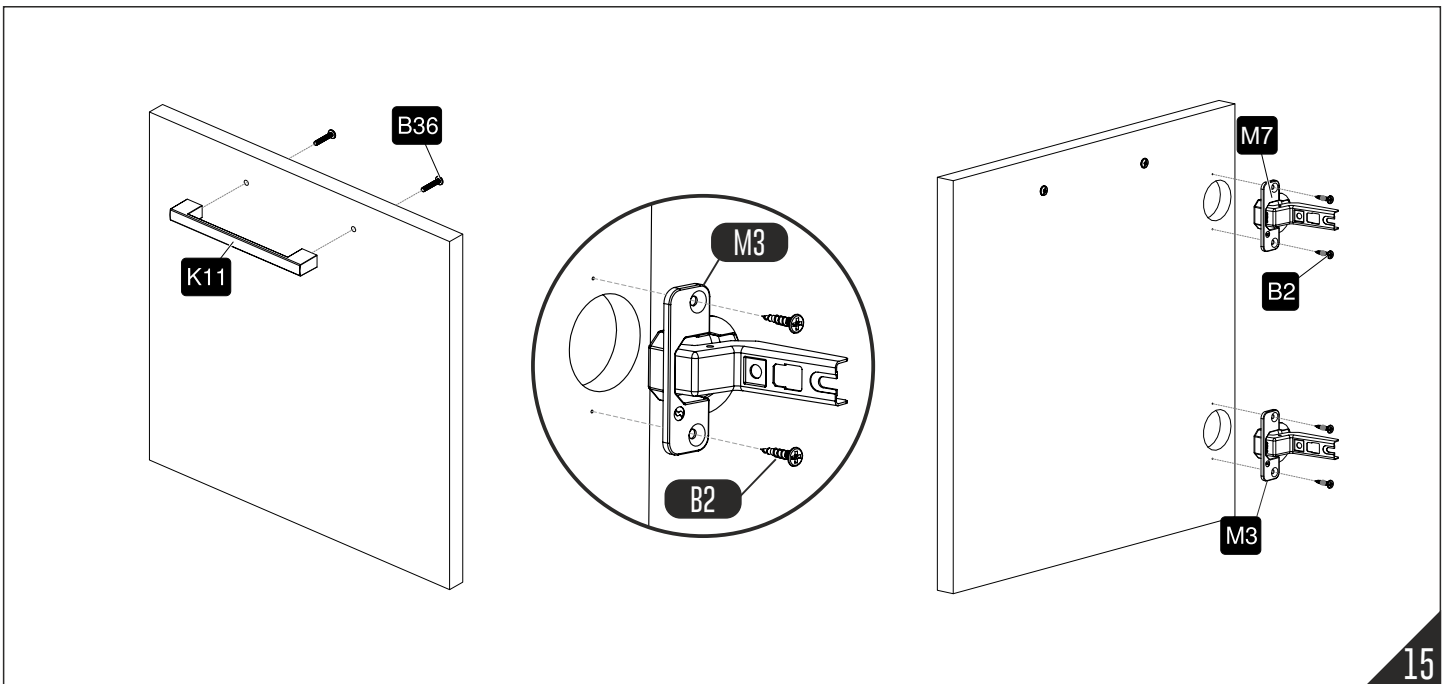

15

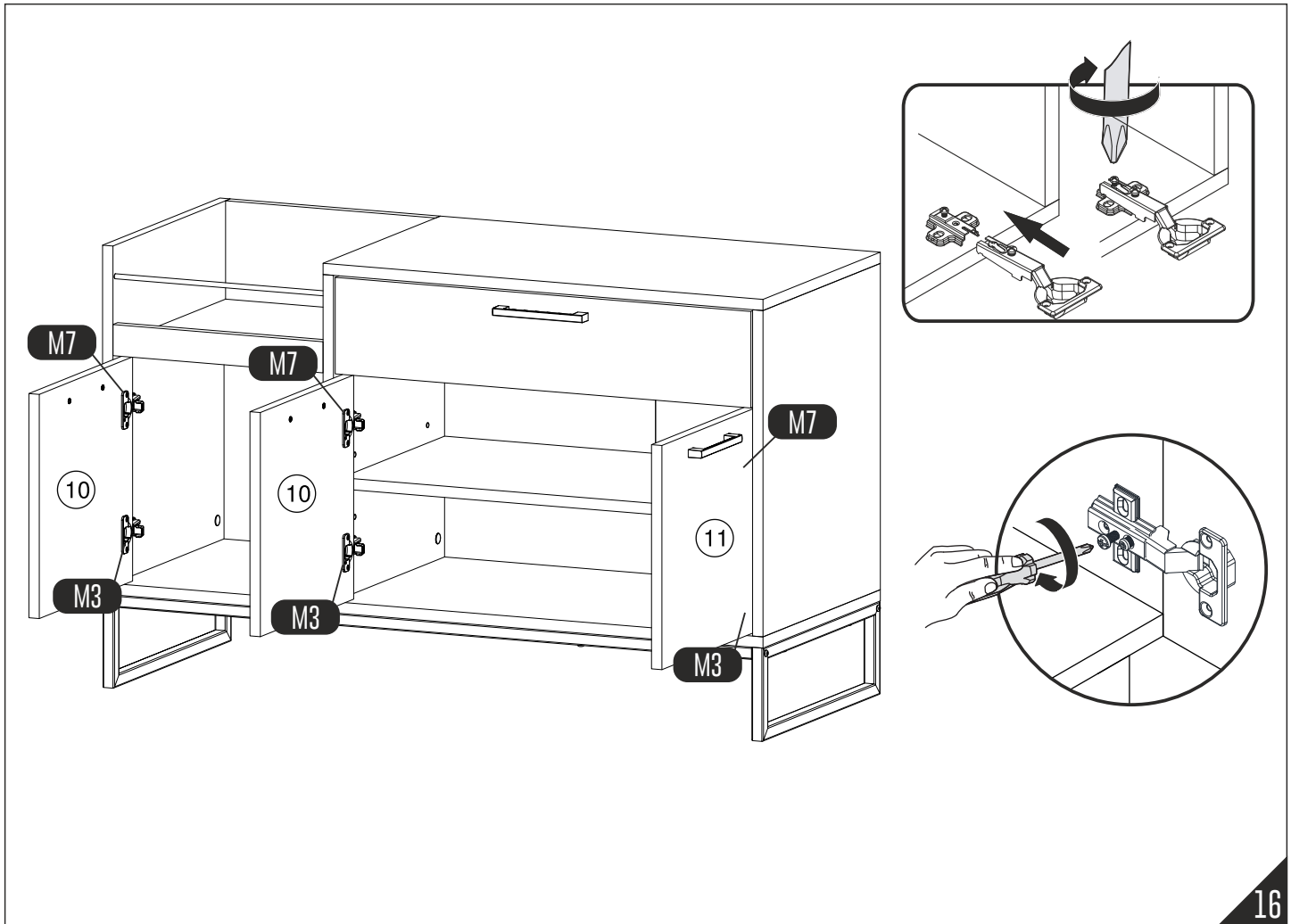

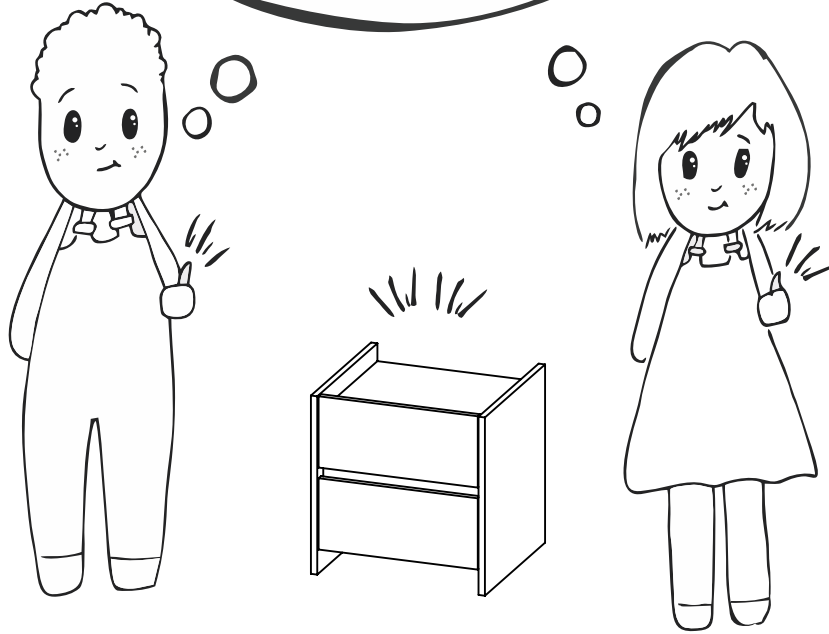

Have you seen our other products ?

[www.furmet.com.tr](http://www.furmet.com.tr)

