

yukon kitaplık

furmet

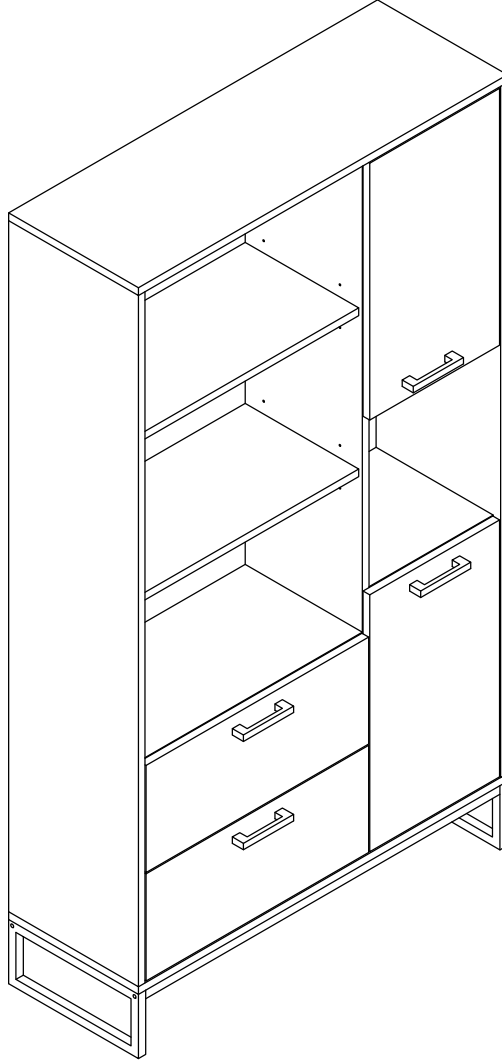

MOYEN-MEDIUM
MITTEL-MEDIO

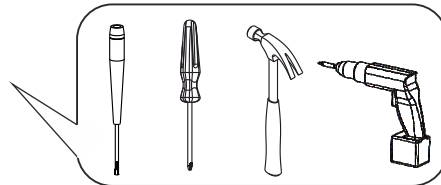
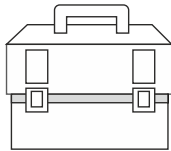
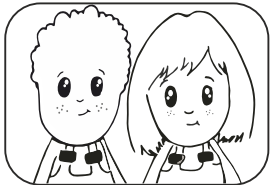

TR/ Eğer ürününüzle ilgili yardıma ihtiyacınız olursa email: info@furmet.com.tr

UK/ If you need information about your product, email: info@furmet.com.tr

GE/ Wenn Sie Fragen zu Ihrem Produkt, email: info@furmet.com.tr

FR/ Si vous avez des questions sur votre produit, email: info@furmet.com.tr

ES/ Si tiene alguna pregunta acerca de su producto, email: info@furmet.com.tr

PT/ Se você tiver dúvidas sobre o seu produto, email: info@furmet.com.tr

SE/ Om du har frågor om din produkt, email: info@furmet.com.tr

NW/ Hvis du trenger informasjon om produktet, email: info@furmet.com.tr

IT/ Se hai delle domande sul tuo articolo, ecco la mail via nuestro website

PL/ Jeśli mają Państwo pytania dotyczące produktu, email: info@furmet.com.tr

RU/ Если Вам необходима дополнительная информация о товаре, свяжитесь с нами по email: info@furmet.com.tr

hey you!

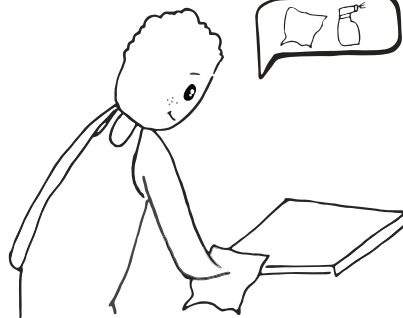
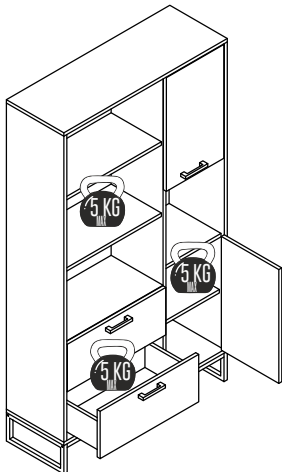
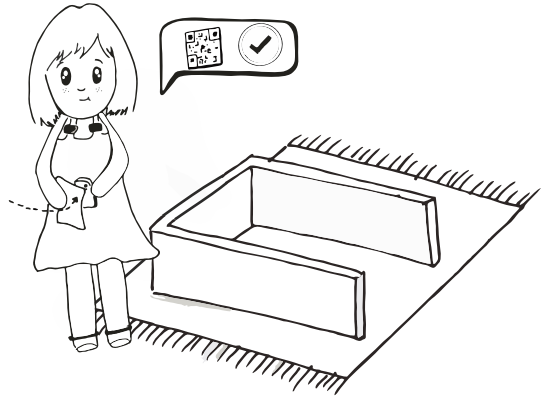
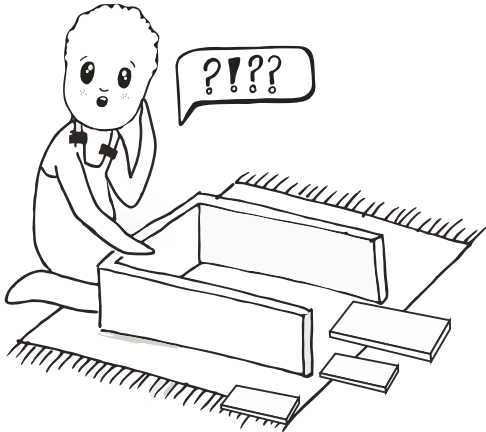
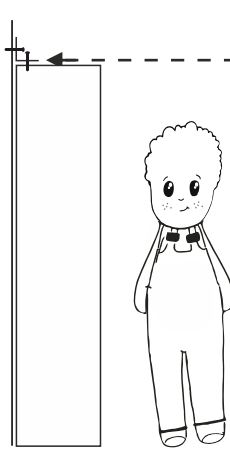
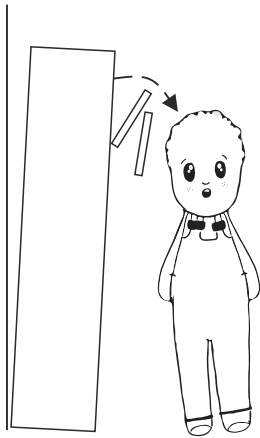
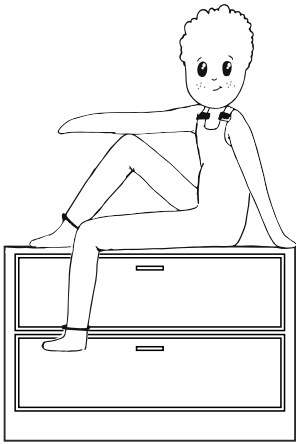

PS: Clean only with a damp cloth.
NOT: Yalnızca nemli bir bezle temizleyiniz.

caution!

Minifix is the main connection material used in products. Before starting assembly, please check the drawings below.

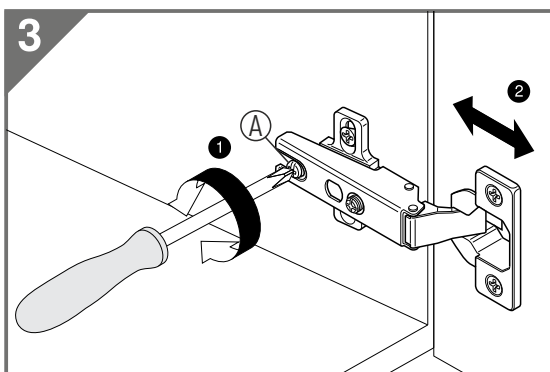
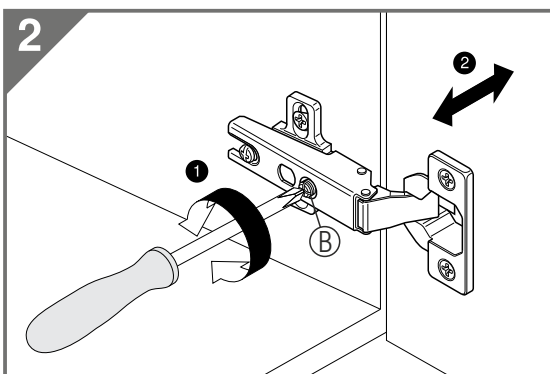
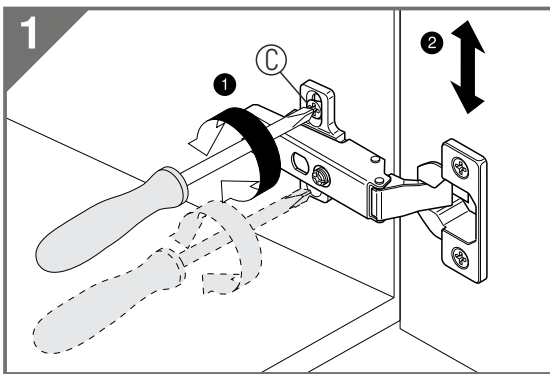
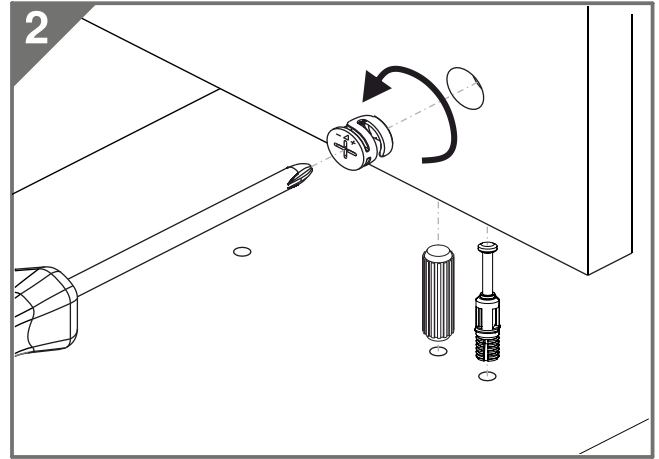
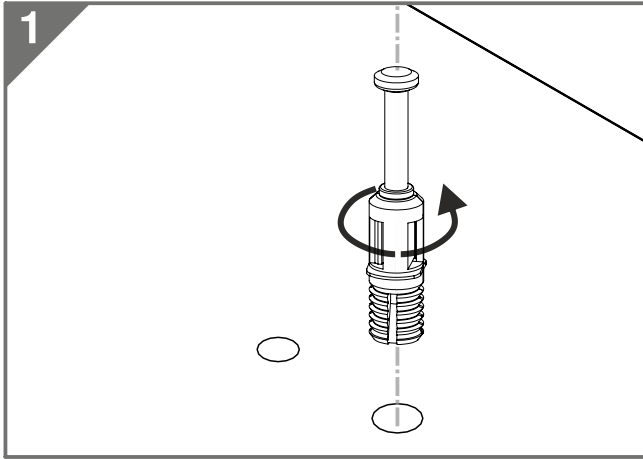

Height adjustment: Loosen screw 'C', adjust height, retighten screw 'C'.

Depth adjustment: Loosen fixing 'A', push hinge arm forwards or backwards, retighten screw 'A', fix screw 'B' with a 1/4- turn in clock-wise direction.

Side adjustment: Loosen fixing screw 'A', adjust gap with screw 'B' and retighten screw 'A'.

TOOLBOX

A1 DÜBELLİ MİNİFİKS MİLİ X34	A2 MİNİFİKS KAFASI X34	A3 KAVELA X24	A6 MİNİFİKS DÜBELİ X8	K11 128mm KÖPRÜ KULP SİYAH X4	Y1 ALYAN X1
M3 SÜPER DEVE MENT. X2	M4 MENTEŞE K. X4	R2 300mm TEKERLEKLİ RAY BEYAZ X2	B30 ARKALIK SIKIŞTIRMA X25	B18 CONFIRMAT VIDA X6	T1 BEYAZ X34
B1 çivi X10	B2 3,5*18 MM X61	B3 DÜBEL X2	B5 5*70 MM X2	B32 6X30 MM ALYAN BAŞLI METAL VİDASI X12	B19 20'LİK KULP VİDASI X8
B10 PLS. RAF PİMİ BEYAZ X16	B11 ASKI APARATI X2	B12 ASKI APARATI X2	P23 20X20 KEÇE X4	M7 FRENLİ SD. MENT. X2	

No.	Qty.
1	1
2	1
3	1
4	1
5	1
6	2
7	2
8	1
9	2
10	1
11	1
12	2
13	2
14	2
15	2
16	2
17	1
18	2
19	2
20	2

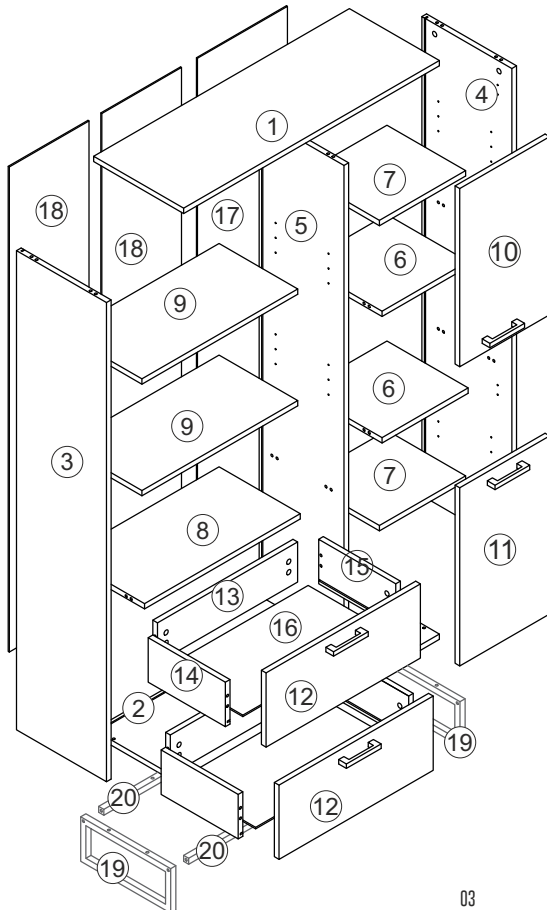

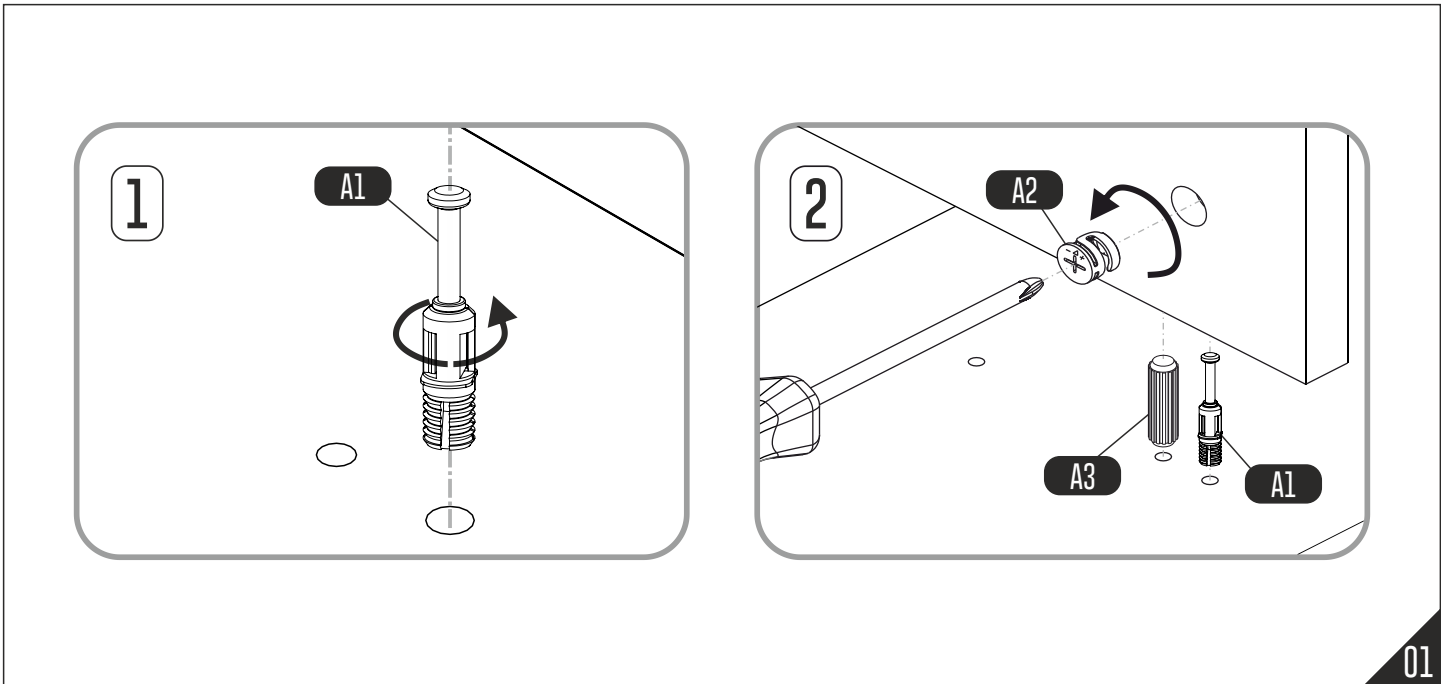

01

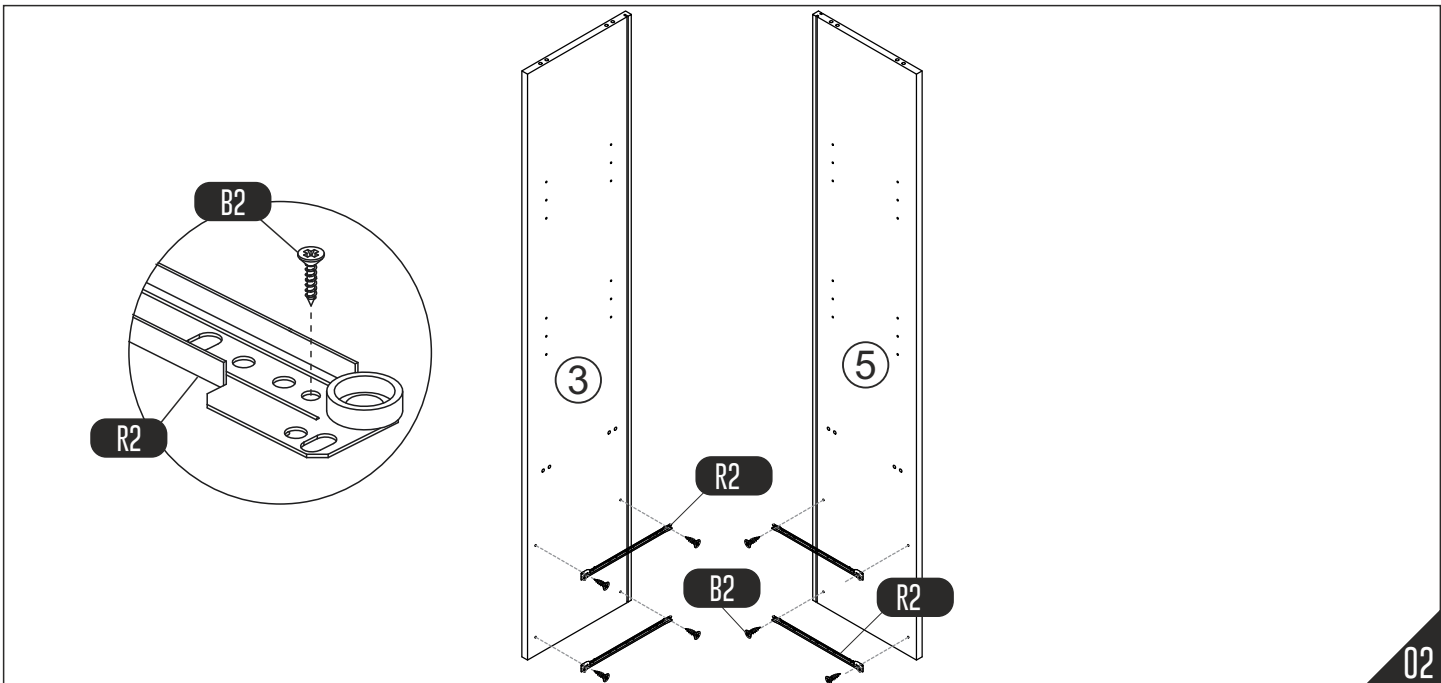

02

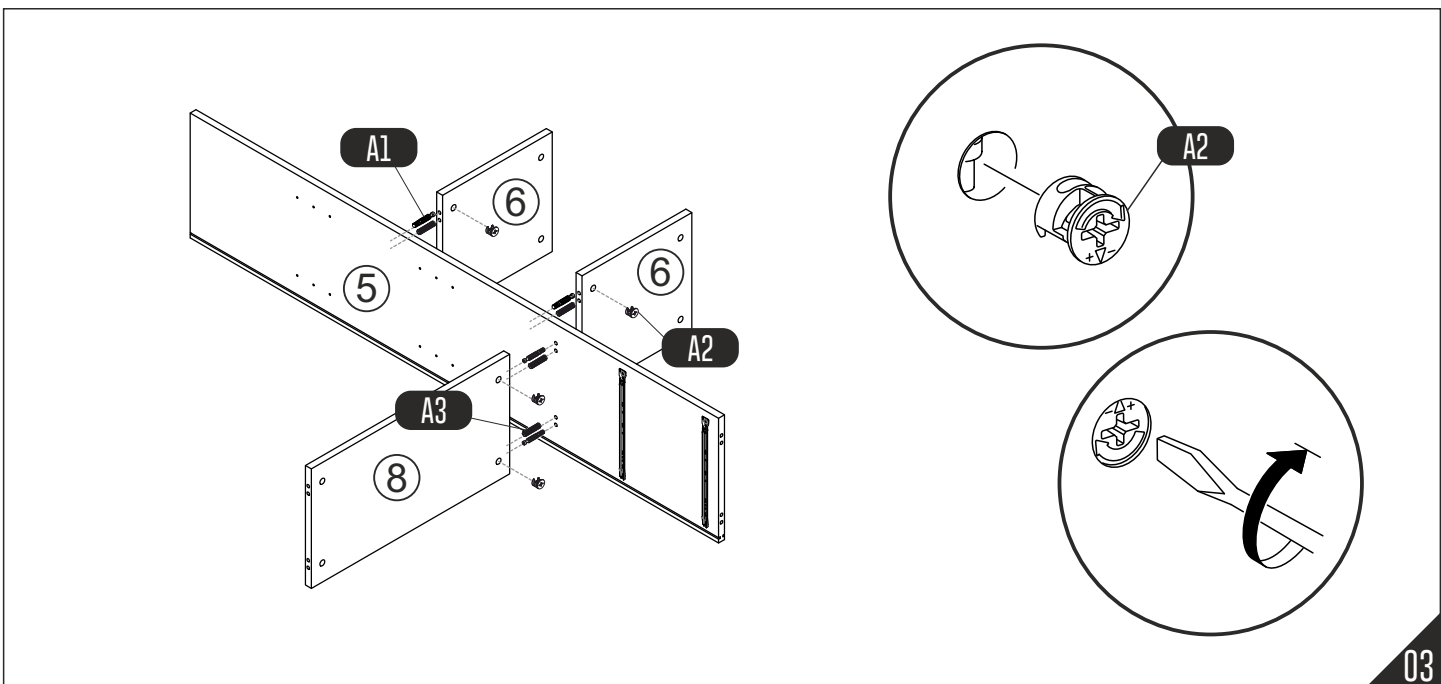

03

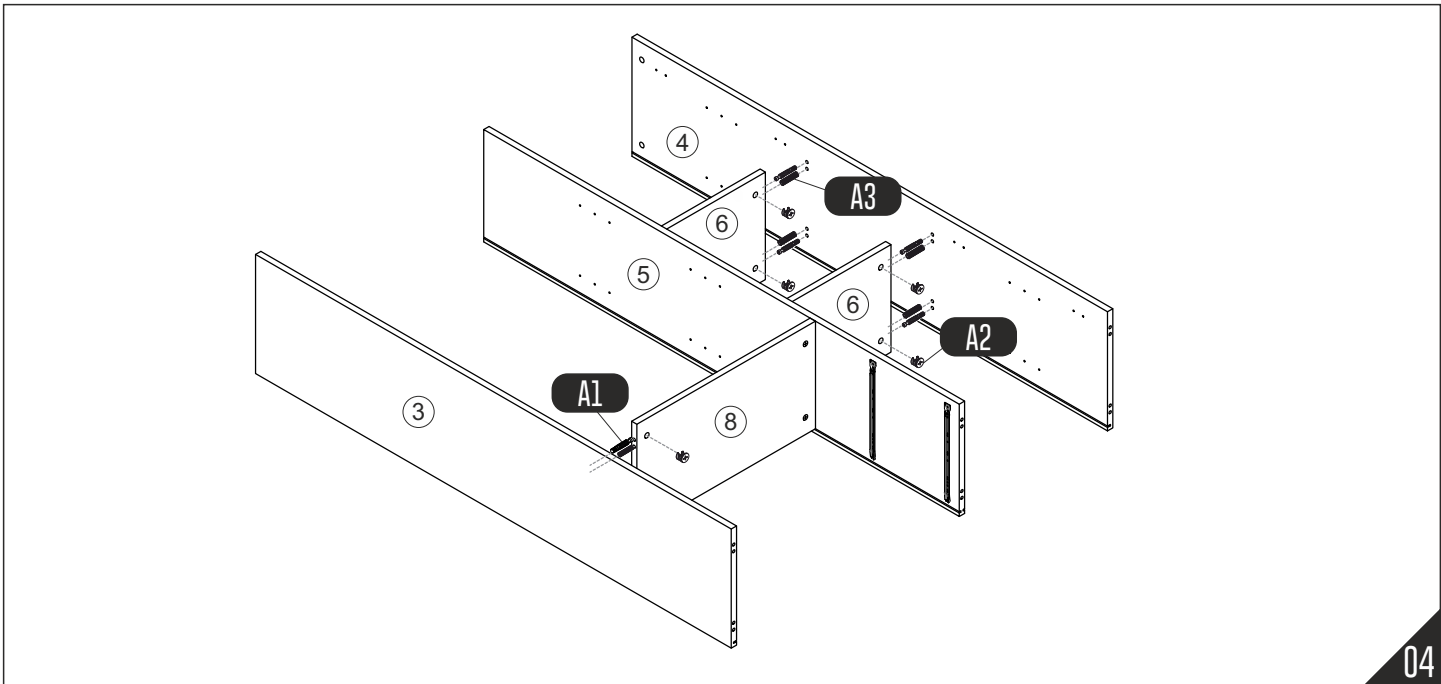

04

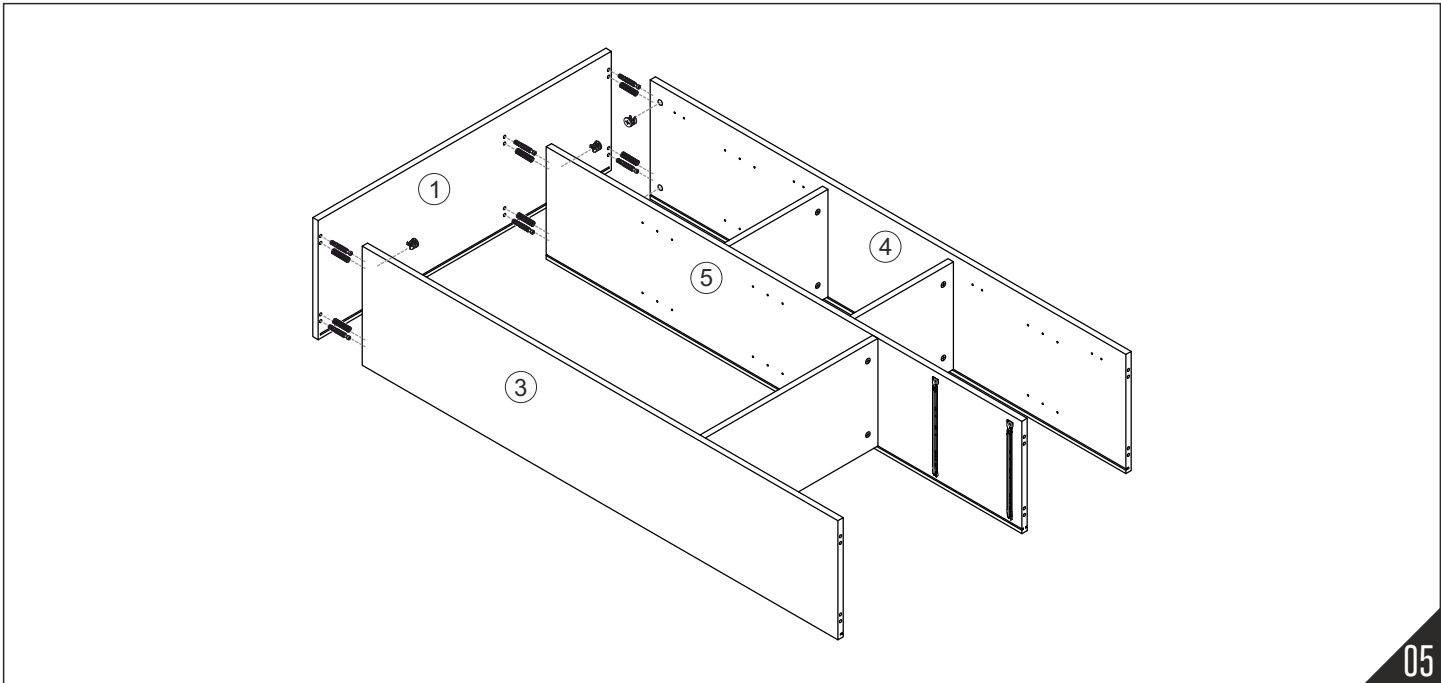

05

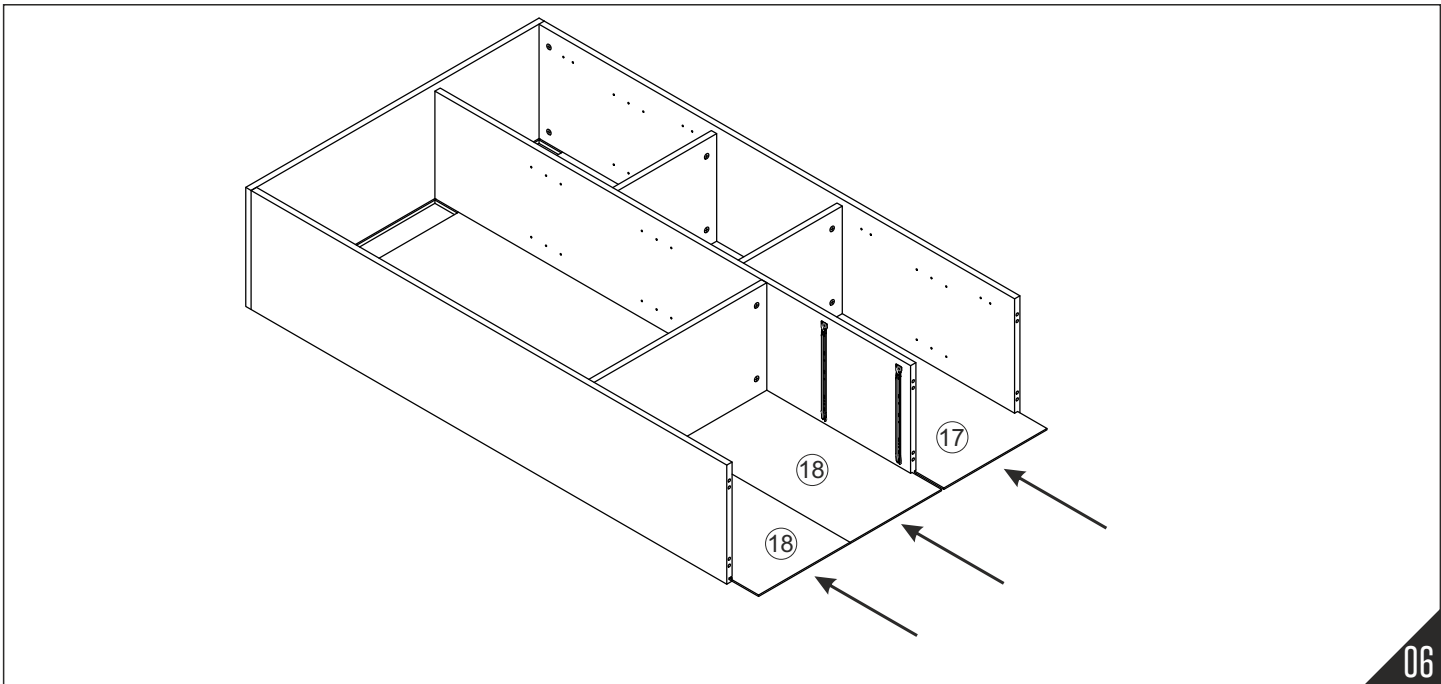

06

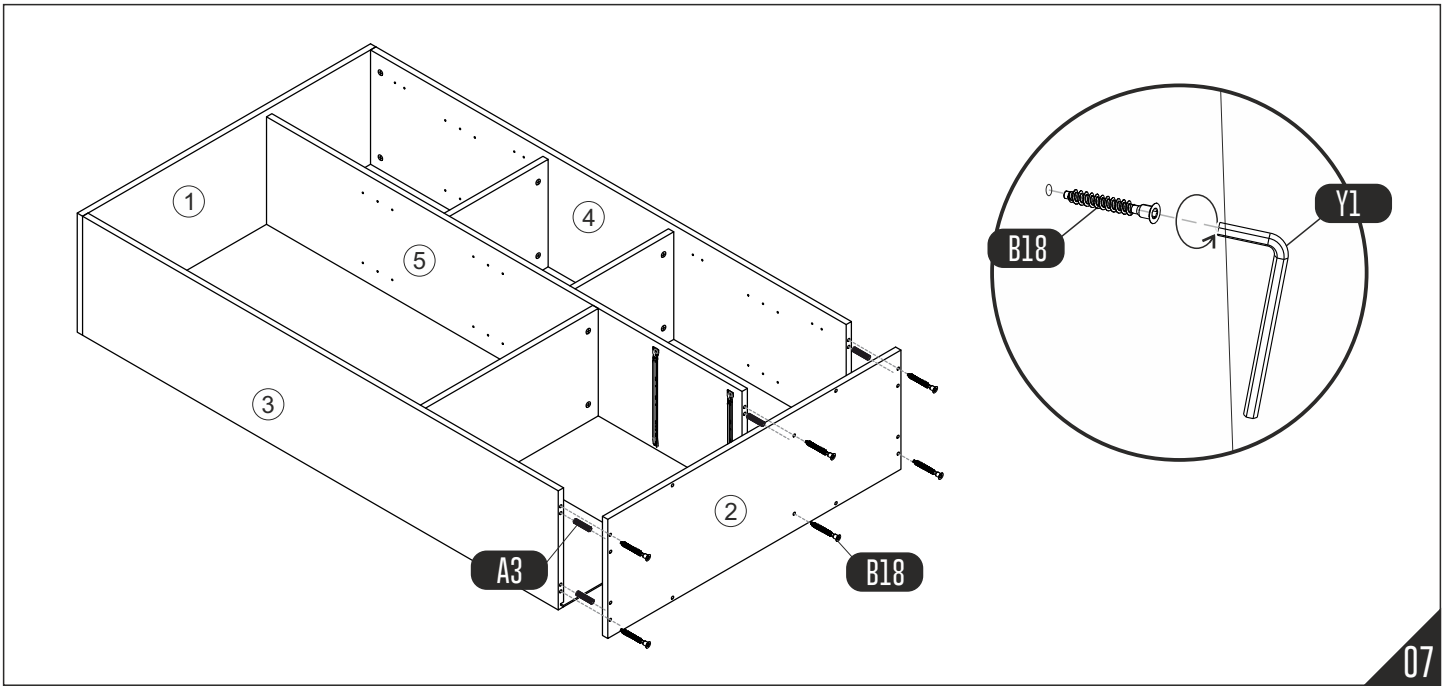

07

Metel ayakları mobilya gövdesiyle birleřtirirken, vidaları aynı anda yerleřtirip eřit bir řekilde sıkalım

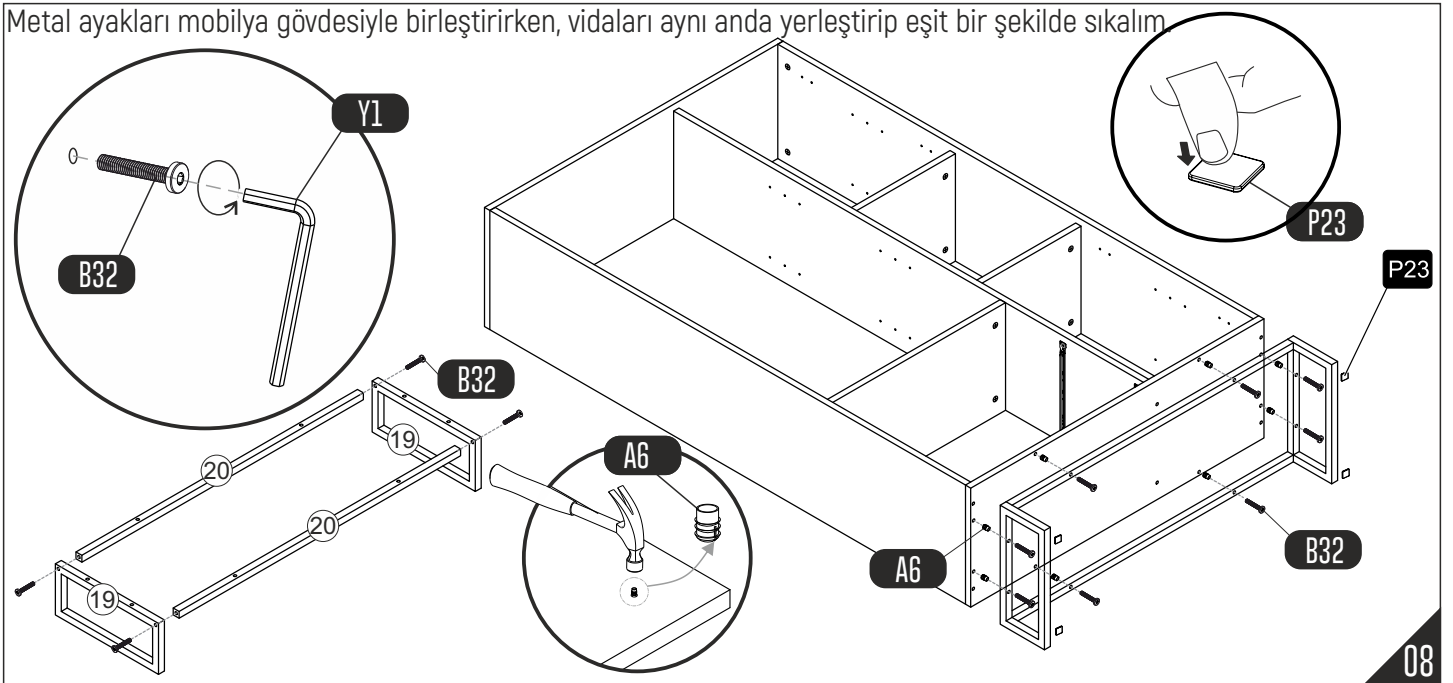

08

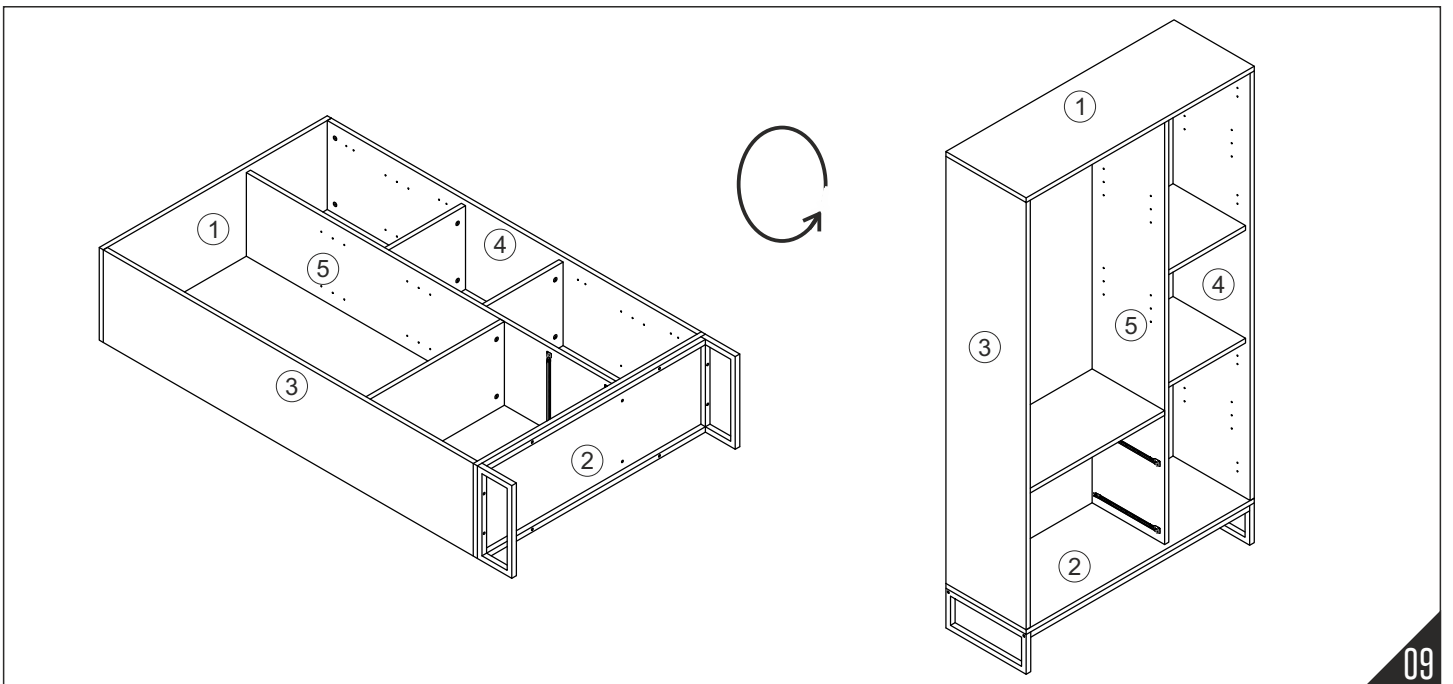

09

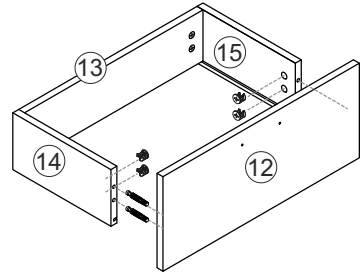
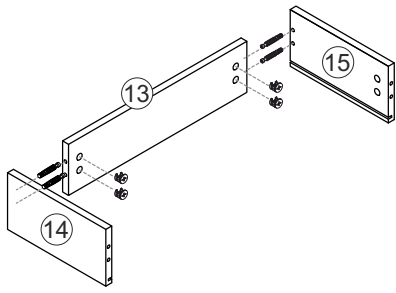

10

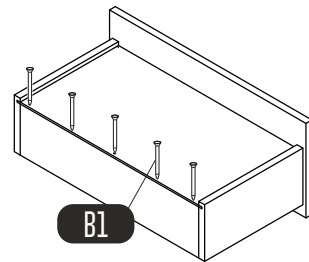
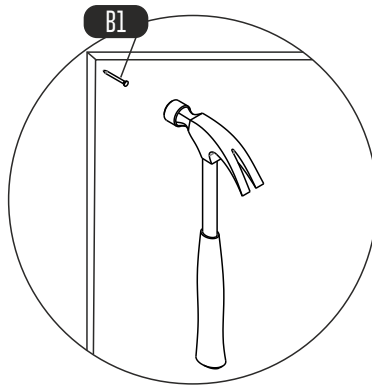
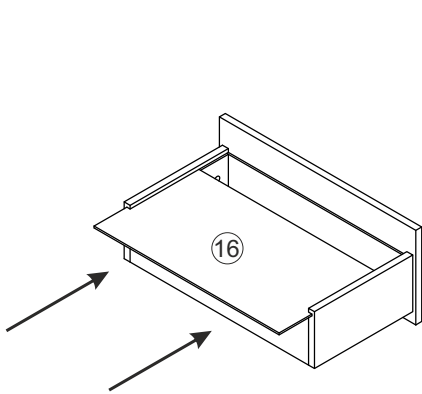

11

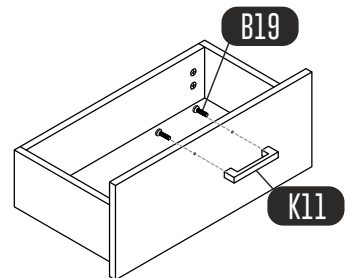
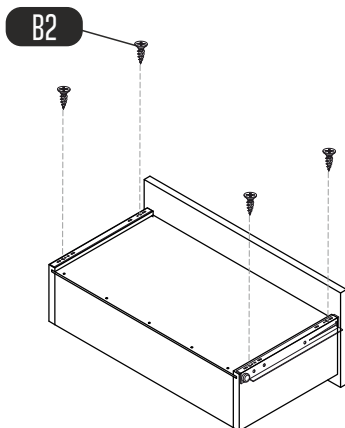

12

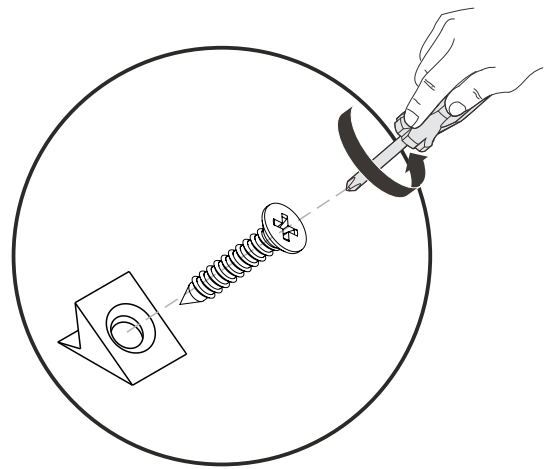
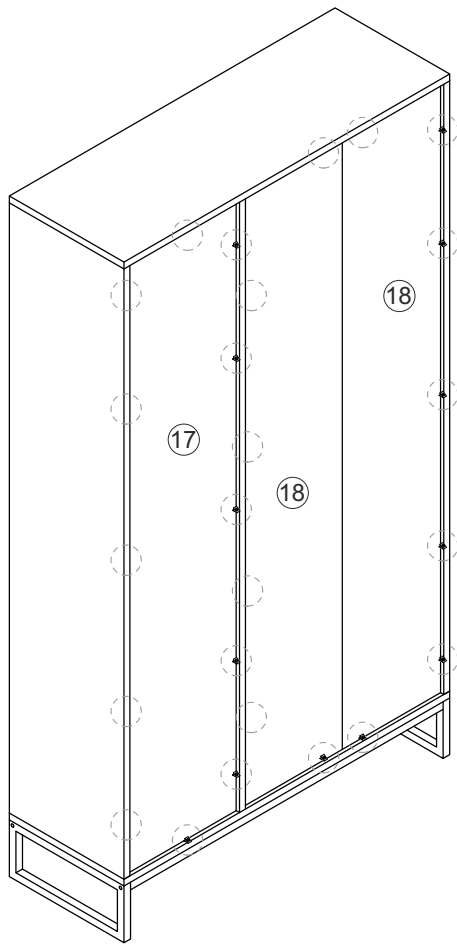

13

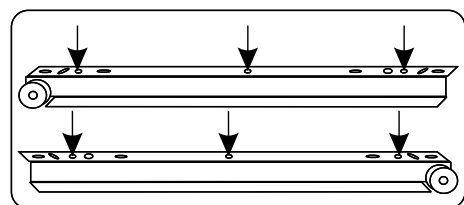
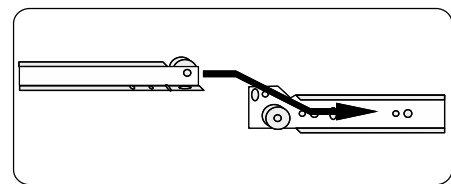
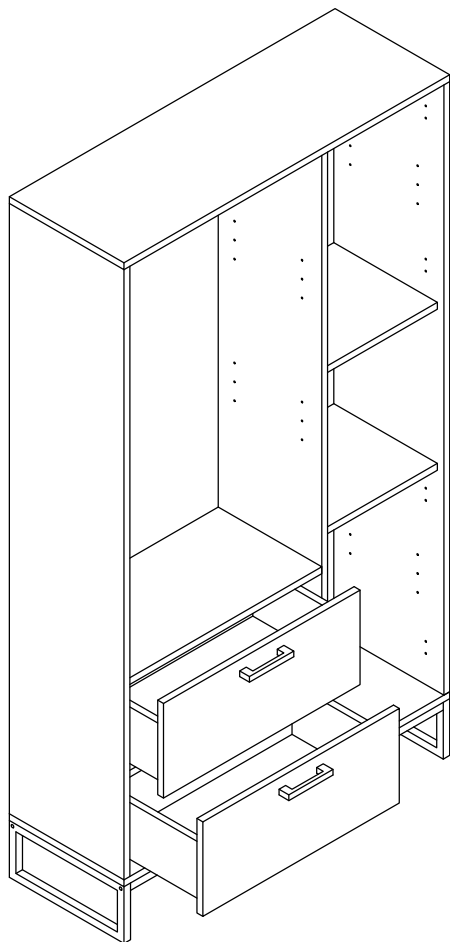

14

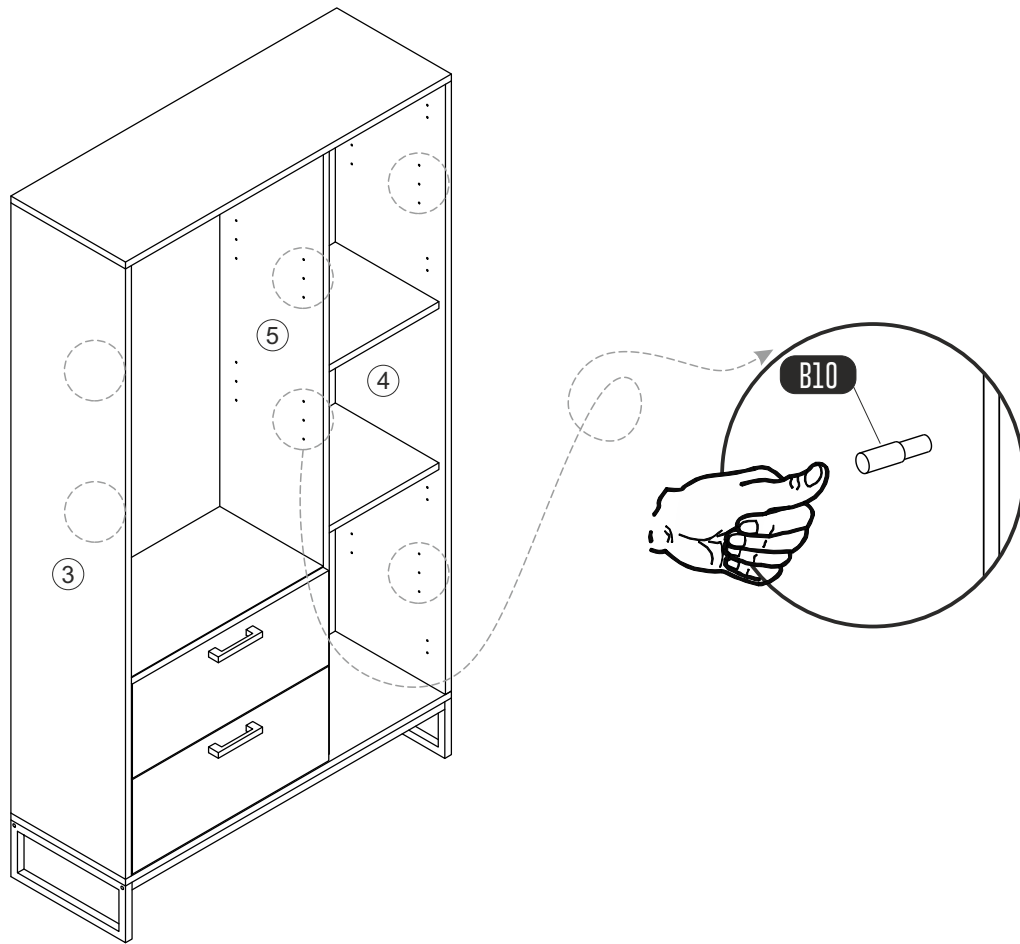

15

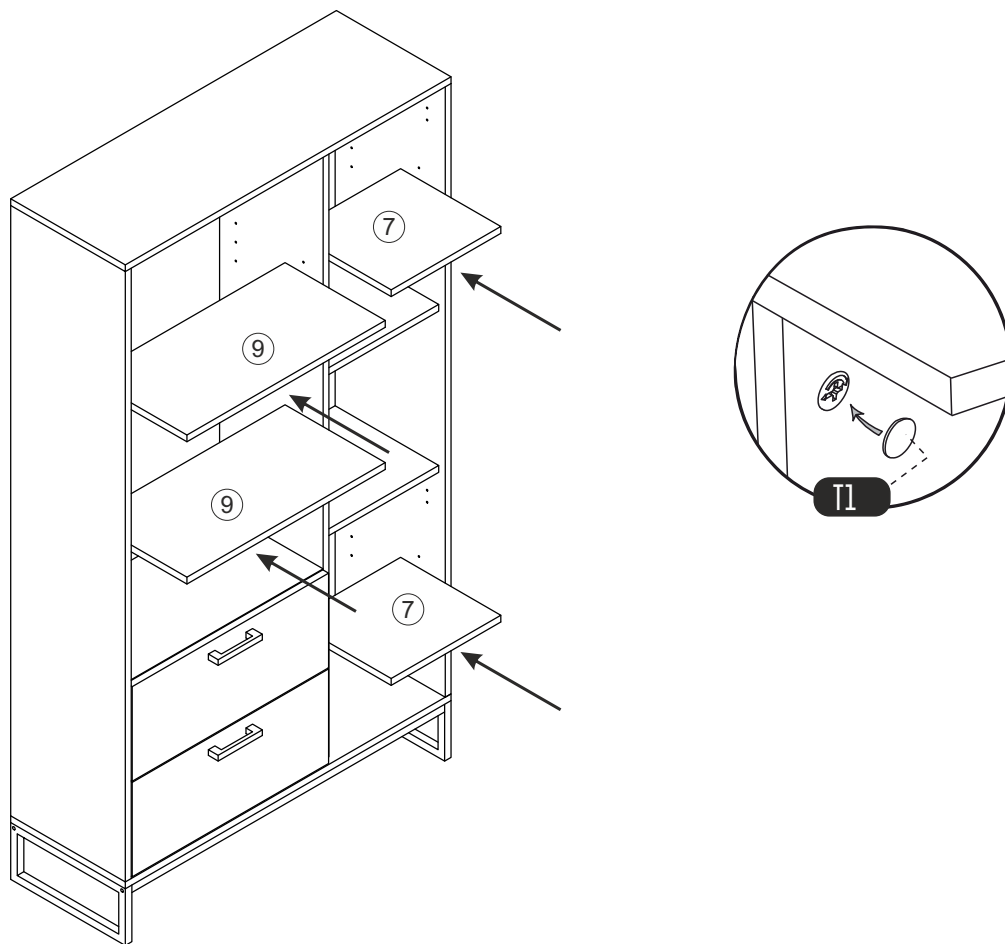

16

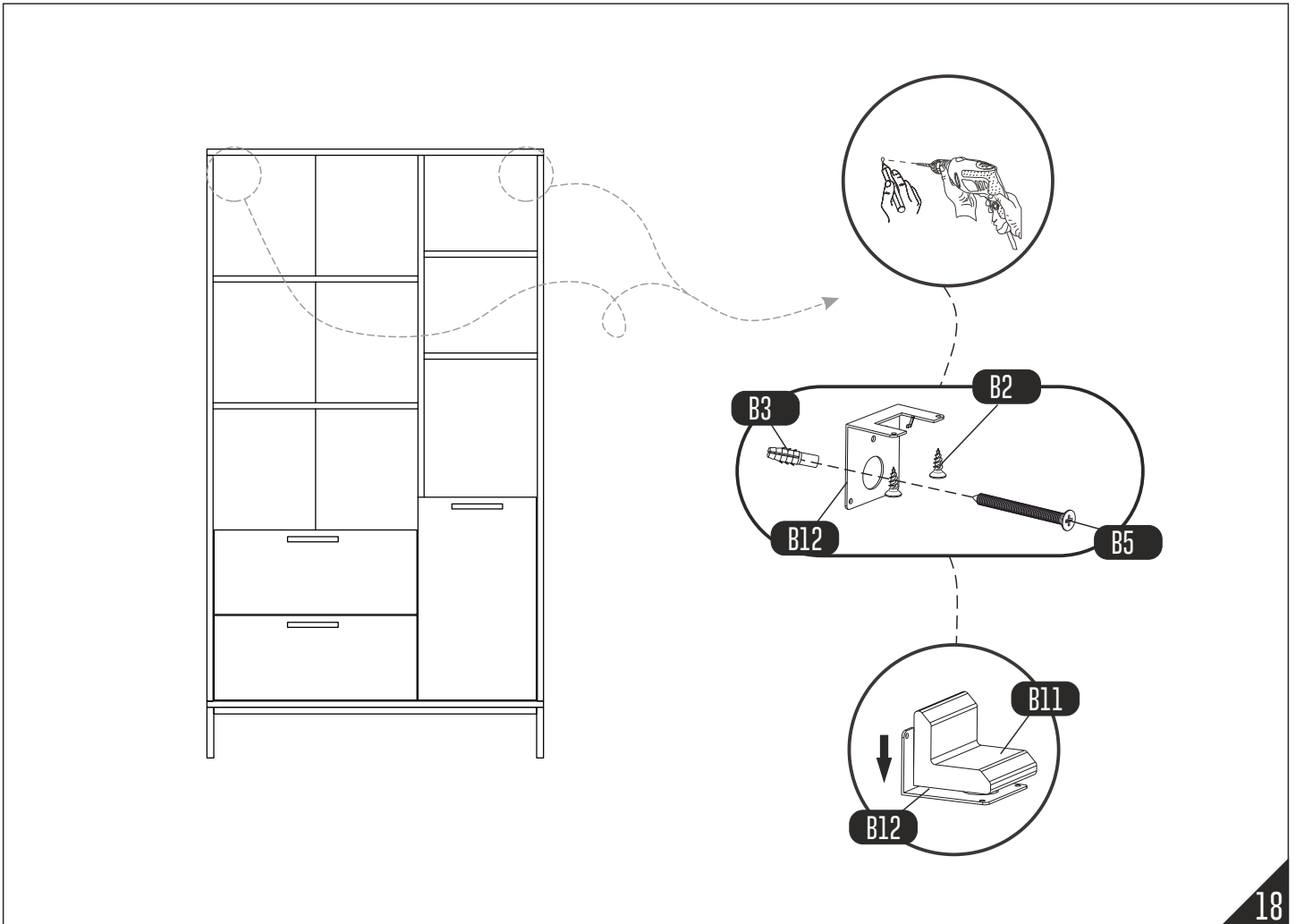
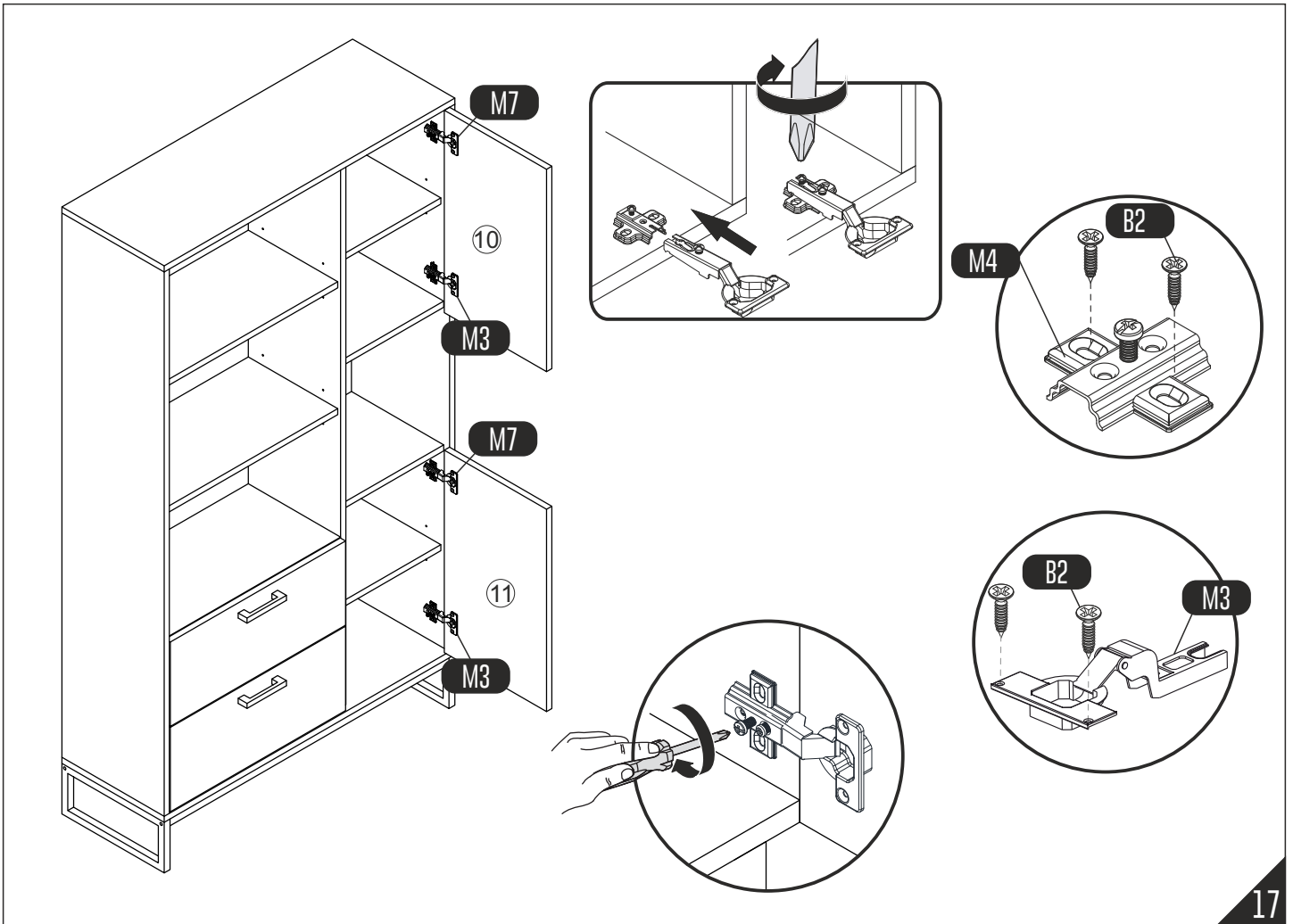

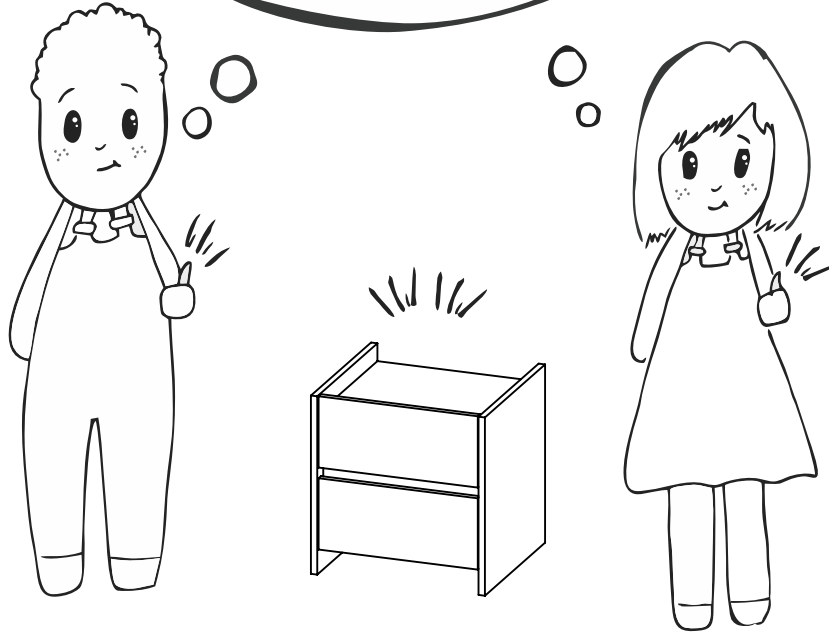

Have you seen our other products ?

www.furmet.com.tr

