

MONTAJ ŞEMASI
(MOUNTING DIAGRAM)İLETİŞİM NUMARASI:
0553 789 08 38

1	PLASTİK KAVELA (PLASTIC COVER)		6 Ad
2	MİNİFİKS GÖVDESİ (MINIFIX BODY)		6 Ad
3	DÜBELLİ MİL (SHAFT WITH PEG)		6 Ad
4	MİNİFİKS TIPASI (MINIFIX PLUG)		6 Ad
5	PLASTİK DÜBEL (PLASTIC PEG)		4 Ad
6	VİDA YHB 4x18 (SCREW YHB 4x18)		18 Ad
7	VİDA YHB 6x70 (SCREW YHB 6x70)		4 Ad
8	ASKI ELEMANI (HANGER COMPONENT)		1 TK
9	MENTEŞE (HINGE)		4 Ad
10	PROFİL TUTUCU (PROFILE HOLDER)		2 Ad
11	KULP (HANDLE)		2 Ad
12	KULP VİDASI (HANDLE SCREW)		4 Ad
13	VİDA YHB 4x30 (SCREW YHB 4x30)		4 Ad
14	VİDA YHB 4x50 (SCREW YHB 4x50)		1 Ad

NOT: AKSESUAR (KULP, RAY VB.) GENEL GÖRÜNÜM AMAÇLI OLUP KATALOG GÖRÜNÜMÜNDEN FARKLI OLABİLİR.
(NOTE: ACCESSORY (HANDLE, RAIL, ETC.) IS FOR GENERAL VIEW AND MAY DIFFER FROM CATALOG VIEW)

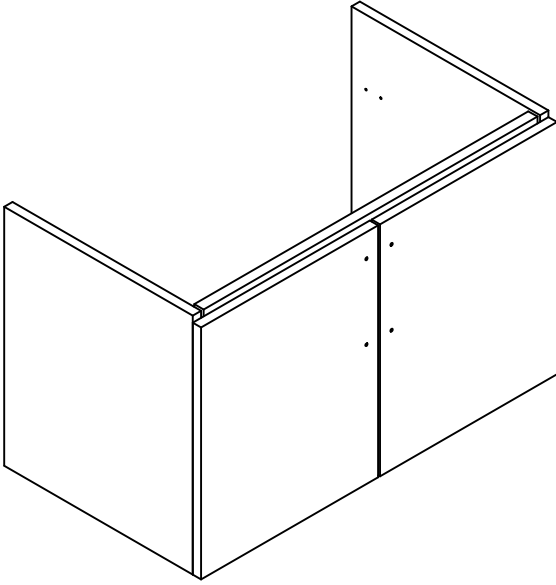
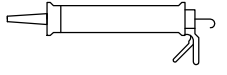
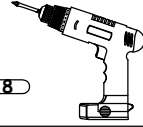
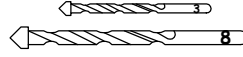
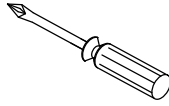
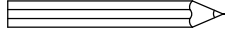
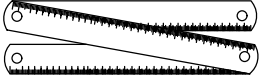

1

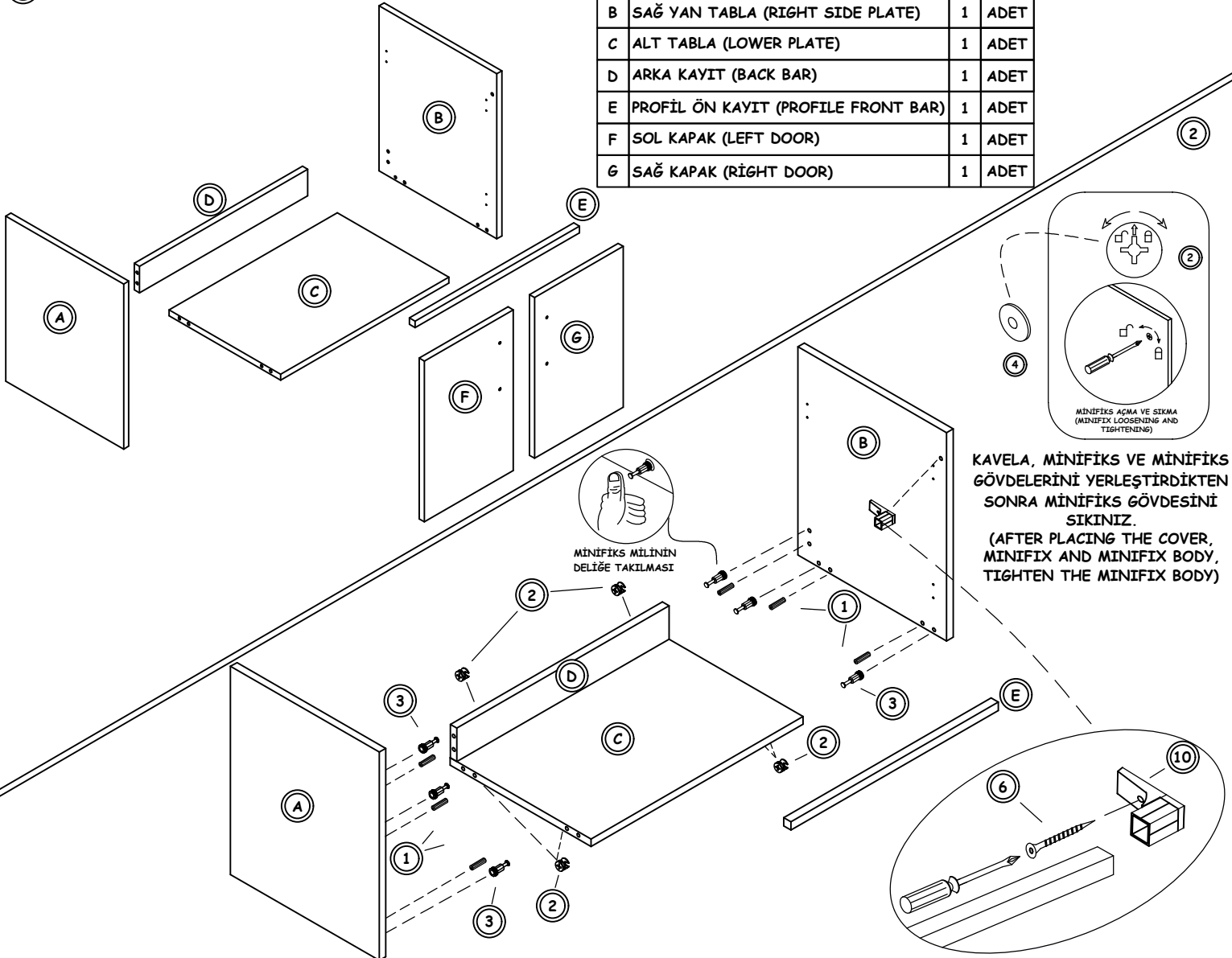

A	SOL YAN TABLA (LEFT SIDE PLATE)	1	ADET
B	SAĞ YAN TABLA (RIGHT SIDE PLATE)	1	ADET
C	ALT TABLA (LOWER PLATE)	1	ADET
D	ARKA KAYIT (BACK BAR)	1	ADET
E	PROFİL ÖN KAYIT (PROFILE FRONT BAR)	1	ADET
F	SOL KAPAK (LEFT DOOR)	1	ADET
G	SAĞ KAPAK (RIGHT DOOR)	1	ADET

KAVELA, MİNİFİKS VE MİNİFİKS GÖVDELERİNİ YERLEŞTİRDİKTEN SONRA MİNİFİKS GÖVDESİNİ SIKINIZ.
(AFTER PLACING THE COVER, MINIFIX AND MINIFIX BODY, TIGHTEN THE MINIFIX BODY)

3

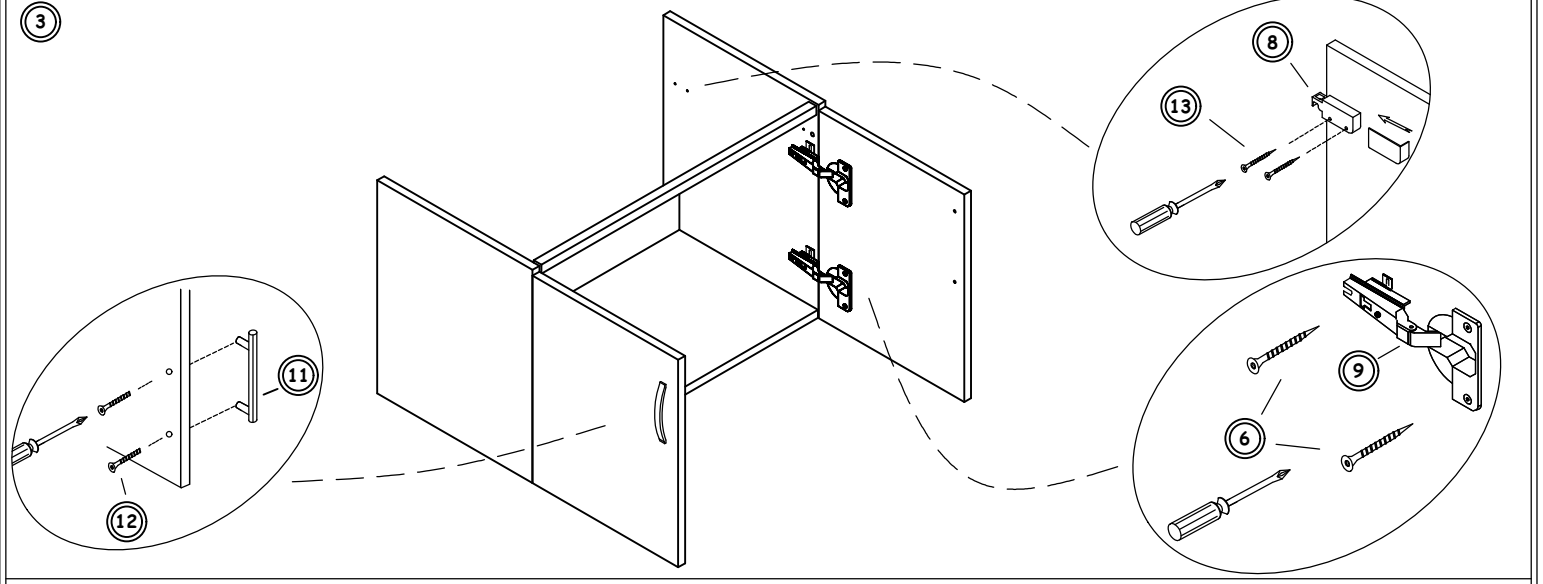

4

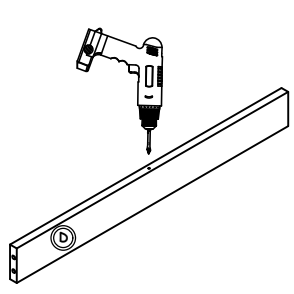

ARKA KAYITI ALT KISIMINDAN ŞEKİLDEKİ GİBİ 3 LÜK MATKAP İLE DELİNİZ. (DRILL THE BACK BAR FROM THE LOWER PART WITH A 3-PIECE DRILL AS SHOWN IN THE FIGURE.)

ALT TABLADA BULUNAN İZ DELİĞİNDEN 4x50 VİDAYI SIKARAK ALT TABLA İLE ARKA KAYITI BİRBİRİNE BAĞLAYINIZ. (CONNECT THE BACK BAR WITH THE LOWER PLATE BY TIGHTENING THE 4x50 SCREW THROUGH THE MARK HOLE LOCATED ON THE LOWER PLATE.)

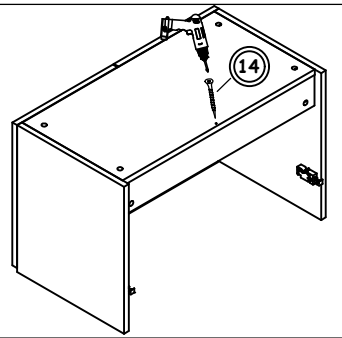

5

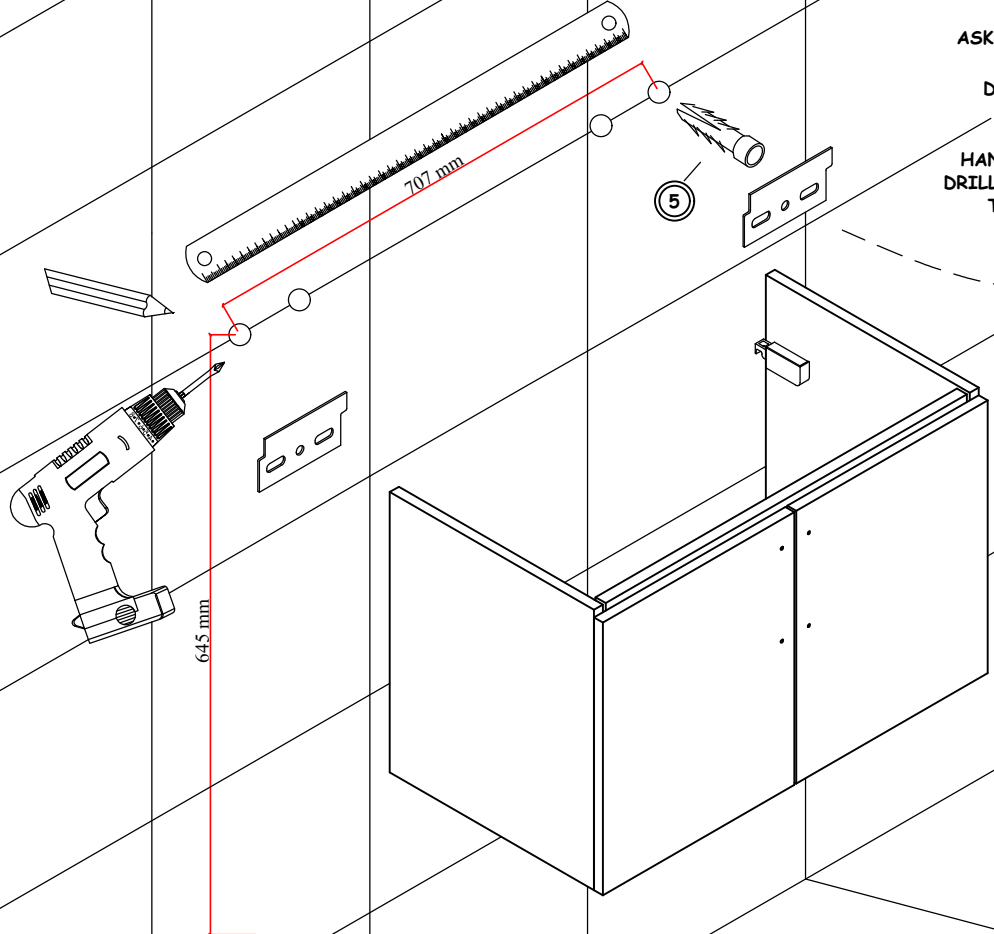

ASKI ELEMANI İÇİN DUVAR DELİKLERİNİ DARBELİ MATKAP İLE DELİNİZ. DUVAR DELİKLERİNİ DELDİKTEN SONRA DÜBELLERİ YERLEŞTİRİN. ASKI ELEMANINI DÜBELE VIDALAYIN. (DRILL THE WALL HOLES FOR THE HANGER COMPONENT WITH IMPACT DRILL. AFTER DRILLING THE WALL HOLES, PLACE THE PEGS. SCREW THE HANGER COMPONENT TO THE ANCHOR)

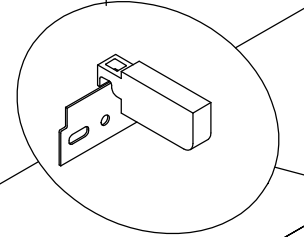
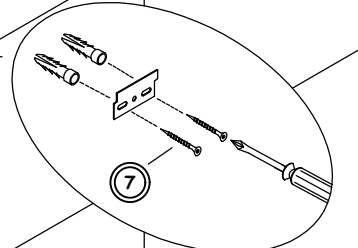

6

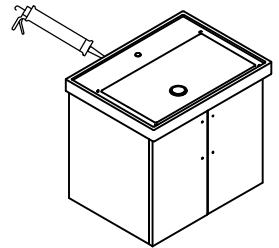
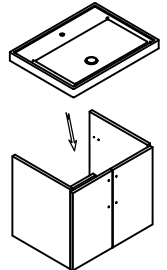

DOLABI ASIP LAVABOYU YERLEŞTİRDİKTEN SONRA LAVABO İLE FAYANS ARASINA SİLİKON SIKILMASI TAVSİYE EDİLİR. (IT IS RECOMMENDED TO APPLY SILICONE BETWEEN THE SINK AND THE TILE AFTER PLACING THE SINK.)